

# Celsite® & Surecan®

Access Port Systems, Accessories  
and Non-Coring Port Needles

# Access Port Systems

## Implantation sites

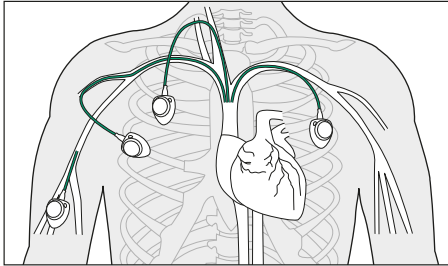

### Venous access

for repeated intravenous administration of treatments such as chemotherapy, antibiotics, antiviral drugs, parenteral nutrition, as well as for blood sampling and transfusions.

# Content

---

## Access Port Systems for venous access

- 4 - 7 **Celsite® Safety**  
High pressure resistant port catheter system  
(PEEK housing and chamber / titanium base plate)
- 8 - 9 **Celsite® Epoxy**  
High pressure resistant port catheter system  
(epoxy housing / titanium chamber)
- 10 - 11 **Celsite® ECG**  
High pressure resistant port catheter system for placement via intra-atrial ECG lead  
(epoxy housing / titanium chamber)
- 12 - 13 **Celsite® Discreet**  
High pressure resistant port catheter system with unique design  
(epoxy housing / titanium chamber)
- 14 - 15 **Celsite® PSU**  
High pressure resistant port catheter system  
(polysulfone housing / titanium chamber)

---

## Safety Access Port Needles

- 16 - 17 **Surecan® Safety II**  
High pressure resistant non-coring safety needle for long term infusions

---

## Non-Safety Access Port Needles

- 18 **Winged Surecan®**  
High pressure resistant non-coring needle for long term infusions

---

## Celsite® Access Port Systems

- 19 **Overview and type declaration**
- 20 - 22 **Accessories**
- 23 - 27 **Customized Access Port Kits**

# Celsite® Safety

High pressure resistant port catheter system  
(PEEK housing and chamber / titanium base plate)



Celsite® Safety is designed for use in conditions requiring mid to long-term intermittent or continuous central venous infusions. Its anatomical design, featuring a low-profile nose, simplifies insertion. Additionally, the system incorporates several safety features, including a high-density silicone septum for reliable sealing, a radiopaque connection ring with anti-kink protection, and an intuitive safety mechanism to reduce the risk of needle stick injuries.

## Reduced titanium content

Minimizes MRI artifacts.

## PEEK Housing and Chamber

- Poly Ether Ether Ketone – A biocompatible material that offers high chemical and pressure resistance with excellent durability.
- Naturally coloured without any additional substances

## Titanium Bottom Plate

Ensures high puncture resistance.

## High pressure resistant and radiopaque CT – marking

- The entire range of Celsite® Safety is resistant to high-pressure injections up to 325 psi.
- Enables power injections of contrast media without the need for additional venous access.
- Provides clear identification of high-pressure resistance under X-ray.

## Large Puncture Area

High-density silicone septum for easy puncturing and reliable sealing, ensuring long port life.

## Extra-Large Suture Holes

Facilitate easy fixation of the access port with sutures.

## Laser-Marked Catheters

Complete range of laser-marked Silicone and PUR catheters with atraumatic tips, marked every cm after the first 5 cm.

## Radiopaque Connection Ring

Provides anti-kink protection and reliable catheter fixation.





**PEEK and titanium combination as special safety features**

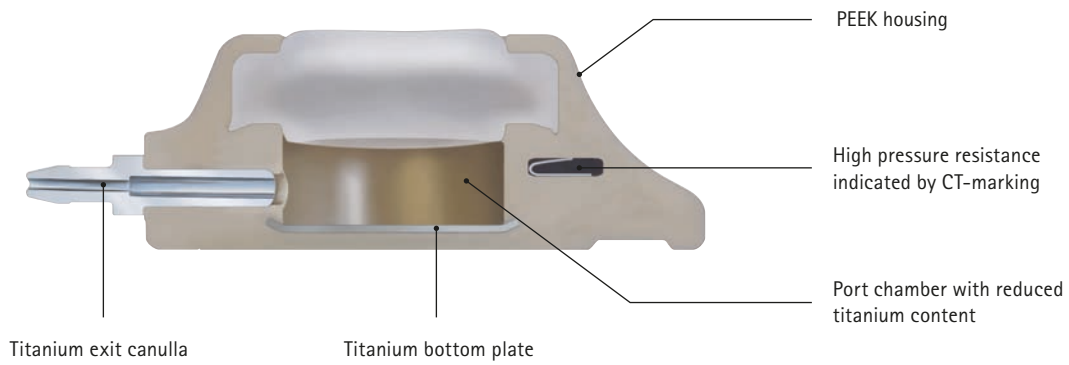

**Surecan® Safety II – Port Needle**

- Intuitive safety mechanism to reduce needle stick injuries.
- High pressure resistance up to 325 psi.



**Safecan™ Safety – Puncture Needle**

- Safety mechanism mechanism to reduce needle stick injuries.
- Echogenic puncture needle for precise tip location via ultrasound.



# Celsite® Safety

Celsite® Safety offers a wide range of Silicone and PUR catheters as well as two different port sizes, Standard and Small.

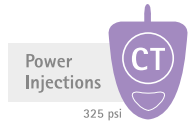

## Celsite® Safety with open suture holes

Catheter	OD (F/mm)	ID (mm)	Length (mm)	Flow rate* (ml/min)		Recommended maximum flow rates (mL/s) Contrast media at 37°C (325 psi = 22.4 bar)**			Implantation technique	Type	Reference	Accessories see page 32
				19 G	22 G	Viscosity up to 11.4 mPa.s (cP)						
						22 G	20 G	19 G				
<b>Standard</b>												
Silicone	6.5 / 2.2	1.1	500	26	10	2	5	5	Surgical cut-down	T601F	4437556	8
Silicone	8.5 / 2.8	1.2	500	34	11	2	5	5	Surgical cut-down	T601L	4437573	8
PUR	6.5 / 2.1	1.4	500	37	12	2	5	5	Surgical cut-down	T601P	4437565	8
PUR	8.5 / 2.8	1.6	500	48	12	2	5	5	Surgical cut-down	T601H	4437581	8
Silicone	6.5 / 2.2	1.1	500	26	10	2	5	5	Seldinger	SST601F	4437603	7
Silicone	8.5 / 2.8	1.2	500	34	11	2	5	5	Seldinger	SST601L	4437612	7
Silicone	10 / 3.2	1.6	500	48	12	2	5	5	Seldinger	SST601G	4437620	7
PUR	6.5 / 2.1	1.4	500	37	12	2	5	5	Seldinger	SST601P	4437607	7
PUR	8.5 / 2.8	1.6	500	48	12	2	5	5	Seldinger	SST601H	4437617	7
<b>Small</b>												
Silicone	6.5 / 2.2	1.1	500	26	10	2	5	5	Surgical cut-down	T605F	4437758	8
Silicone	10 / 3.2	1.6	500	48	12	2	5	5	Surgical cut-down	T605G	4437786	8
Silicone	6.5 / 2.2	1.1	500	26	10	2	5	5	Seldinger	SST605F	4437803	7
Silicone	8.5 / 2.8	1.2	500	34	11	2	5	5	Seldinger	SST605L	4437817	7
Silicone	10 / 3.2	1.6	500	48	12	2	5	5	Seldinger	SST605G	4437822	7
PUR	5 / 1.6	1.1	500	26	10	2	5	5	Seldinger	SST605C	4437800	7
PUR	6.5 / 2.1	1.4	500	37	12	2	5	5	Seldinger	SST605P	4437809	7
PUR	8.5 / 2.8	1.6	500	48	12	2	5	5	Seldinger	SST605H	4437813	7

\* Gravity infusion of saline (0.9%) through a 22G respectively 19G needle from a height difference of 1 m and a catheter length of 40 cm. According to ISO 10555-1

\*\* Flow rates determined according to ISO 10555-6 with a catheter of 20 cm and Surecan® Safety II and winged Surecan® 20 G needle

**Standard**

**Material:** Titanium | PEEK  
**Weight:** 8 g  
**Internal Volume:** 0.5 mL

**Small**

**Material:** Titanium | PEEK  
**Weight:** 5 g  
**Internal Volume:** 0.3 mL

**PVC**  
FREE

**LATEX**  
FREE

\* Gravity infusion of saline (0.9%) through a 22G respectively 19G needle from a height difference of 1 m and a catheter length of 40 cm. According to ISO 10555-1

\*\* Flow rates determined according to ISO 10555-6 with a catheter of 20 cm and Surecan Safety II and winged Surecan 20 G needle

# Celsite® Safety

## Additional references with ultrasound cover and silicone plugs

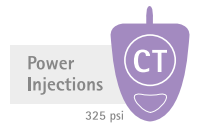

### Celsite® Safety with Ultrasound cover

Catheter	OD (F/mm)	ID (mm)	Length (mm)	Flow rate** (ml/min)		Recommended maximum flow rates (mL/s) Contrast media at 37°C (325 psi = 22.4 bar)**			Implantation technique	Type	Reference	Accessories see page 32
				19 G	22 G	Viscosity up to 11.4 mPa.s (cP)						
						22 G	20 G	19 G				
<b>Standard</b>												
Silicone	6.5 / 2.2	1.1	500	26	10	2	5	5	Seldinger	SNT601F (US Probe)	4437592	11
Silicone	8.5 / 2.8	1.2	500	34	11	2	5	5	Seldinger	SNT601L (US Probe)	4437593	11
<b>Small</b>												
Silicone	6.5 / 2.2	1.1	500	26	10	2	5	5	Seldinger	SNT605F (US Probe)	4437594	11
Silicone	8.5 / 2.8	1.2	500	34	11	2	5	5	Seldinger	SNT605L (US Probe)	4437595	11

\* Available in CE marked countries

\*\* Gravity infusion of saline (0.9%) through a 22G respectively 19G needle from a height difference of 1 m and a catheter length of 40 cm. According to ISO 10555-1

\*\*\* Flow rates determined according to ISO 10555-6 with a catheter of 20 cm and Surecan® Safety II and winged Surecan® 20 G needle



### Celsite® Safety with Silicone plugs

Catheter	OD (F/mm)	ID (mm)	Length (mm)	Flow rate* (ml/min)		Recommended maximum flow rates (mL/s) Contrast media at 37°C (325 psi = 22.4 bar)**			Implantation technique	Type	Reference	Accessories see page 32
				19 G	22 G	Viscosity up to 11.4 mPa.s (cP)						
						22 G	20 G	19 G				
<b>Standard</b>												
Silicone	6.5 / 2.2	1.1	500	26	10	2	5	5	Seldinger	SST701F	4437605	7
Silicone	8.5 / 2.8	1.2	500	34	11	2	5	5	Seldinger	SST701L	4437614	7
Silicone	10 / 3.2	1.6	500	48	12	2	5	5	Seldinger	SST701G	4437621	7
PUR	6.5 / 2.1	1.4	500	37	12	2	5	5	Seldinger	SST701P	4437609	7
Silicone	6.5 / 2.2	1.1	500	26	10	2	5	5	Surgical cut-down	T701F	4437560	8
Silicone	8.5 / 2.8	1.2	500	34	11	2	5	5	Surgical cut-down	T701L	4437578	8
<b>Small</b>												
Silicone	6.5 / 2.2	1.1	500	26	10	2	5	5	Seldinger	SST705F	4437805	7
Silicone	8.5 / 2.8	1.2	500	34	11	2	5	5	Seldinger	SST705L	4437818	7
Silicone	10 / 3.2	1.6	500	48	12	2	5	5	Seldinger	SST705G	4437790	7
PUR	5 / 1.6	1.1	500	26	10	2	5	5	Seldinger	SST705C	4437801	7
PUR	6.5 / 2.1	1.4	500	37	12	2	5	5	Seldinger	SST705P	4437807	7
PUR	8.5 / 2.8	1.6	500	48	12	2	5	5	Seldinger	SST705H	4437815	7

\* Gravity infusion of saline (0.9%) through a 22G respectively 19G needle from a height difference of 1 m and a catheter length of 40 cm. According to ISO 10555-1

\*\* Flow rates determined according to ISO 10555-6 with a catheter of 20 cm and Surecan® Safety II and winged Surecan® 20 G needle

# Celsite® Epoxy

## High pressure resistant port catheter system (epoxy housing / titanium chamber)

As the premium access port range from B. Braun, Celsite® Epoxy ports offer outstanding features and an extensive portfolio of various port sizes and catheters. They are designed for repeated intravenous administration of treatments such as chemotherapy, antibiotics, antiviral drugs, parenteral nutrition, blood sampling, and transfusions.



### Compact Design

Low-profile design with a large septum relative to the port dimensions.

### Extended Portfolio

Available in extra small Brachial and Babyport® versions, making it one of the most compact access ports available.

### High-Pressure Resistant and Radiopaque CT-Marking

- The entire range of Celsite® Epoxy is resistant to high-pressure injections up to 325 psi.
- Enables power injections of contrast media without the need for additional venous access.
- Provides clear identification of high-pressure resistance under X-ray.

### Large Puncture Area

High-density silicone septum for easy puncturing and reliable sealing, ensuring long port life.

### Suture Holes

Facilitates easy fixation of the access port with sutures.

### Laser-Marked Catheters

Complete range of Silicone and PUR catheters with atraumatic tips, marked every centimeter.

### Radiopaque Connection Ring

Provides anti-kink protection and reliable catheter fixation.



Catheter	OD (F/mm)	ID (mm)	Length (mm)	Flow rate* (ml/min)		325 PSI Recommended maximum flow rates (mL/s) Contrast media at 37°C (325 psi = 22.4 bar)**						Implantation technique	Type	Reference	Accessories see page 30/31
						Viscosity 5.8 mPa.s (cP)			Viscosity 11.4 mPa.s (cP)						
						19 G	22 G	22 G	20 G	19 G	22 G				
<b>Standard</b>															
PUR	5 / 1.6	1.1	900	24	10	2	5	6	1	3	5	Seldinger	ST201C	04432045	1
Silicone	6.5/2.2	1.1	800	26	10	2	6	7	1	4	5	Surgical cut-down	T201F	04430034	6
Silicone	6.5/2.2	1.1	800	26	10	2	6	7	1	4	5	Seldinger	ST201F	04430409	1
PUR	6.5/2.1	1.4	800	34	11	2	5	7	1	4	6	Seldinger	ST201P	04430417	1
PUR (high flow)	8.5/2.8	1.6	800	45	12	2	6	8	1	4	7	Seldinger	ST201H	04433149	1
Silicone	8.5/2.8	1.1	800	28	13	2	6	7	1	4	6	Surgical cut-down	T201	04430026	6
Silicone	8.5/2.8	1.1	800	28	13	2	6	7	1	4	6	Seldinger	ST201	04430395	1
Silicone (high flow)	10 / 3.2	1.6	800	47	13	2	6	9	1	4	6	Seldinger	ST201G	04433807	1
<b>Small</b>															
Silicone	6.5/2.2	1.1	800	24	10	2	5	8	1	4	6	Seldinger	ST205	04430893	1
Silicone	6.5/2.2	1.1	800	24	10	2	5	8	1	4	6	Surgical cut-down	T205	04430085	6
PUR	6.5/2.1	1.4	800	30	11	2	5	8	1	4	5	Seldinger	ST205P	04430894	1
Silicone	8.5/2.8	1.1	800	25	10	2	5	8	1	3	6	Seldinger	ST205L	04430895	1
PUR (high flow)	8.5/2.8	1.6	800	37	12	2	6	9	1	4	6	Seldinger	ST205H	04436806	1
Silicone***	6.5/2.2	1.0	800	24	10	2	5	8	1	4	6	Seldinger	ST215	04430143	1
<b>Baby/Brachial</b>															
PUR	4.5/1.5	0.8	800	12	7	2	4	-	1	3	-	Seldinger	Babyport®	04433742	4
PUR	5 / 1.6	1.1	700	22	10	2	5	-	1	4	-	Seldinger, OTW	Brachial	04433734	10
Silicone	6 / 2.0	1.2	600	24	10	2	5	-	1	4	-	Seldinger	Babyport® S	04433842	5

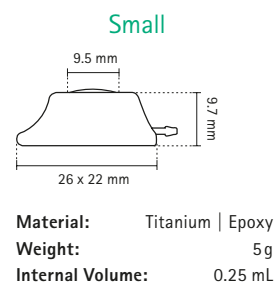
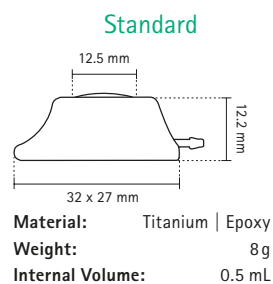

**PVC  
FREE**

**LATEX  
FREE**

\* Gravity flow rates established by gravity infusion of NaCl 0.9%, height 1 m. Catheter length 40 cm. According to ISO 10555-1.

\*\* With a catheter of 20 cm and Surecan® Safety II and winged Surecan® 20 G needle. For countries under CE mark only.

\*\*\* With pre-connected catheter.

# Celsite® ECG

High pressure resistant port catheter system for placement via intra-atrial ECG lead (epoxy housing / titanium chamber)

Celsite® ECG allows precise catheter positioning using intra-atrial ECG detection, ensuring accurate placement of the catheter tip into the superior vena cava without the need for intraoperative fluoroscopy. This system includes radiopaque CT marking for clear identification under X-ray. Correct and accurate positioning of the catheter is crucial to reduce the risk of long-term complications\*.



\* Caers J., Support Care Cancer (2005) 13:325–331

## Acceptance

Proven in daily clinical routine and numerous clinical trials.

## Accurate Placement

Allows precise positioning of the catheter tip into the superior vena cava using intra-atrial ECG detection, reducing the need for intraoperative fluoroscopy.

## High-Pressure Resistant and Radiopaque CT-Marking

- The entire range of Celsite® ECG is resistant to high-pressure injections up to 325 psi.
- Enables power injections of contrast media without the need for additional venous access.
- Provides clear identification of high-pressure resistance under X-ray.

## No X-ray Required

Eliminates the need for expensive X-ray equipment in most cases, reducing exposure for both patients and medical staff.

## Compatibility

Requires the Certodyn® universal adapter for connection to ECG monitors, compatible with all common ECG monitors of the CF device type. The device must be ordered separately (REF 4150228).



Catheter	OD (F/mm)	ID (mm)	Length (mm)	Flow rate* (ml/min)		325 PSI Recommended maximum flow rates (mL/s) Contrast media at 37°C (325 psi = 22.4 bar)**						Implantation technique	Type	Reference	Accessories see page 30/31
						Viscosity 5.8 mPa.s (cP)			Viscosity 11.4 mPa.s (cP)						
				19 G	22 G	22 G	20 G	19 G	22 G	20 G	19 G				

**Standard**

Silicone	6.5 / 2.2	1.0	500	26	10	2	6	7	1	4	5	Seldinger	ST201F ECG	04440140	9
Silicone	6.5 / 2.2	1.0	500	26	10	2	6	7	1	4	5	Surgical cutdown	T201F ECG	04440150	14
Silicone	8.5 / 2.8	1.1	500	28	13	2	6	7	1	4	6	Seldinger	ST201 ECG	04430140	9
Silicone	8.5 / 2.8	1.1	500	28	13	2	6	7	1	4	6	Surgical cutdown	T201 ECG	04430150	14

**Small**

Silicone	6.5 / 2.2	1.0	500	24	10	2	5	8	1	4	6	Seldinger	ST205F ECG	04440111	9
Silicone	6.5 / 2.2	1.0	500	24	10	2	5	8	1	4	6	Surgical cutdown	T205F ECG	04440222	14
Silicone	8.5 / 2.8	1.1	500	25	10	2	5	8	1	3	6	Seldinger	ST205 ECG	04430111	9
Silicone	8.5 / 2.8	1.1	500	25	10	2	5	8	1	3	6	Surgical cutdown	T205 ECG	04430222	14

**Localization**

- 1 When the catheter reaches the right atrium, the P wave begins to rise. The maximum amplitude of the P wave is reached when the catheter enters the right atrium. Note that the amplitude of the P wave decreases as the catheter is advanced into the inferior vena cava. Advance the catheter an additional 2 cm when the P wave begins to reach its maximum amplitude, which corresponds anatomically to the connection between the superior vena cava and the right atrium.
- 2 This point marks the final position of the catheter tip. As the procedure is performed with the patient in the supine position, this catheter position accommodates the 2-3 cm cranial movement of the catheter that occurs when the patient stands.

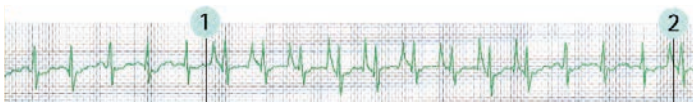
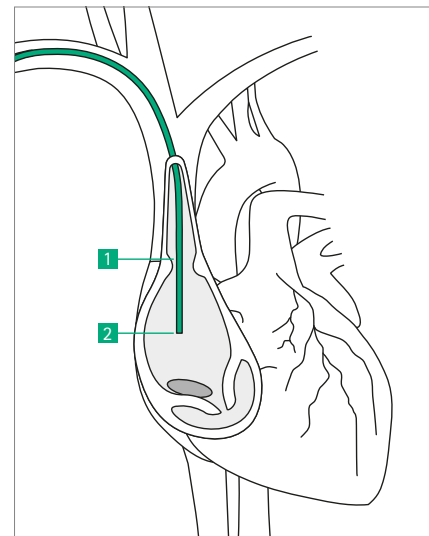

Bitte HiRes Datei liefern

PVC FREE

LATEX FREE

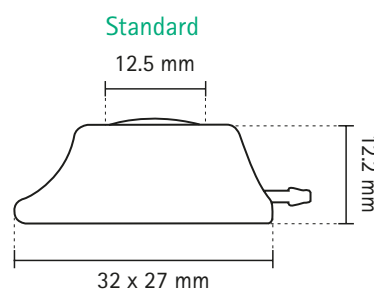

Material: Titanium | Epoxy  
Gewicht: 8g  
Reservoir: 0.5 mL

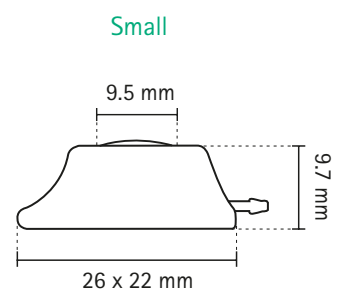

Material: Titanium | Epoxy  
Gewicht: 5g  
Reservoir: 0.25 mL

\* Gravity flow rates established by gravity infusion of NaCl 0.9%, height 1 m. Catheter length 40 cm. According to ISO 10555-1.

\*\* With a catheter of 20 cm and Surecan® Safety II and winged Surecan® 20 G needle. For countries under CE mark only.

# Celsite® Discreet

High pressure resistant port catheter system with unique design  
(epoxy housing / titanium chamber)

Celsite® Discreet features a unique design that ensures better cosmetic results for patients. Its low-profile design with a patented 90° connection provides a high level of discretion. Additionally, it is available in a small size to facilitate implantation in pediatric and underweight patients.



## Low Profile Design

The epoxy housing offers a low-profile design with a patented 90° connection, providing better cosmetic results for the patient.

## High Pressure Resistant and Radiopaque CT-Marking

- The entire range of Celsite® Discreet is resistant to high-pressure injections up to 325 psi.
- Enables power injections of contrast media without the need for additional venous access.
- Provides clear identification of high-pressure resistance under X-ray.

## Prevention of Port Flip

The 90° angle of the exit cannula reduces the risk of port flip.

## Better Cosmetic Results

The surgical incision can be made vertically and the port can be placed laterally following the subcutaneous traction lines.

Catheter	Exit can- nula	OD (F/mm)	ID (mm)	Length (mm)	Flow rate* (ml/min)	325 PSI Recommended maximum flow rates (mL/s) Contrast media at 37°C (325 psi = 22.4 bar)**						Implantation technique	Type	Reference	Accessories see page 30/31
						Viscosity 5.8 mPa.s (cP)			Viscosity 11.4 mPa.s (cP)						
						19 G	22 G	22 G	20 G	19 G	22 G				

**Standard**

Silicone	left	8.5/2.8	1.1	800	28	13	2	6	7	1	4	6	Seldinger	STL201L	04430144	1
Silicone	right	8.5/2.8	1.1	800	28	13	2	6	7	1	4	6	Seldinger	STR201L	04430145	1
PUR	left	8.5/2.8	1.6	800	45	12	2	6	8	1	4	7	Seldinger	STL201H	04440201	1
PUR	right	8.5/2.8	1.6	800	45	12	2	6	8	1	4	7	Seldinger	STR201H	04440202	1

**Small**

Silicone	left	6.5/2.2	1.1	800	24	10	2	5	8	1	4	6	Seldinger	STL205F	04430146	1
Silicone	right	6.5/2.2	1.1	800	24	10	2	5	8	1	4	6	Seldinger	STR205F	04430147	1
PUR	left	6.5/2.1	1.4	800	30	11	2	5	8	1	4	5	Seldinger	STL205P	04440203	1
PUR	right	6.5/2.1	1.4	800	30	11	2	5	8	1	4	5	Seldinger	STR205P	04440204	1

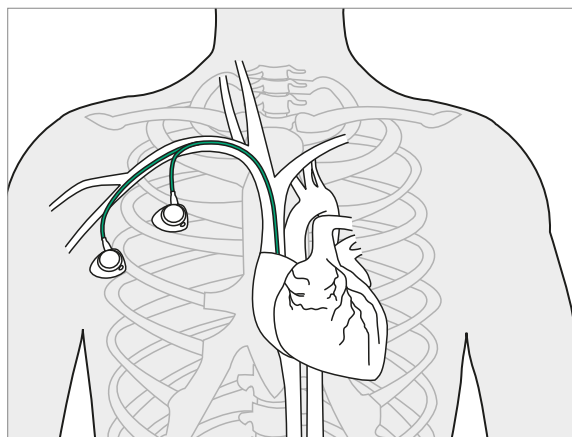

Options for placement of the Celsite® Discreet with vertical incision.



CT-Marking of Celsite® Discreet

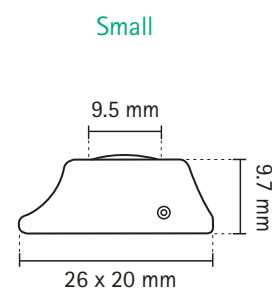

**PVC  
FREE**

**LATEX  
FREE**

**Material:** Titanium | Epoxy  
**Weight:** 7g  
**Internal Volume:** 0.5 mL

**Material:** Titanium | Epoxy  
**Weight:** 4g  
**Internal Volume:** 0.25 mL

\* Gravity flow rates established by gravity infusion of NaCl 0.9%, height 1 m. Catheter length 40 cm. According to ISO 10555-1.

\*\* With a catheter of 20 cm and Surecan® Safety II and winged Surecan® 20 G needle. For countries under CE mark only.

# Celsite® PSU

## High pressure resistant port catheter system (polysulfone housing / titanium chamber)

The Celsite® PSU features a polysulfone housing with a titanium chamber, ensuring durability and high-pressure resistance up to 325 psi. The anatomic design includes a low-profile nose that simplifies insertion and enhances patient comfort. The silicone septum provides reliable sealing for punctures, while the rounded body design allows for easier palpation. The flat base increases stability, and three suture holes facilitate secure fixation of the port.



### Compact Design

The low-profile nose simplifies insertion into the port pocket and enhances patient comfort.

The rounded housing design around the septum allows for easier palpation.

### Stability

The flat base increases stability during use.

### High-Pressure Resistant and Radiopaque CT-Marking

- The entire range of Celsite® PSU is resistant to high-pressure injections up to 325 psi.
- Enables power injections of contrast media without the need for additional venous access.

### Additional Suture Holes

Three suture holes facilitate secure fixation of the port.

### Laser-Marked Catheters

Complete range of laser-marked Silicone and PUR catheters with atraumatic tips, graduated from 5 cm.

### Radiopaque Connection Ring

Provides anti-kink protection and reliable catheter fixation.

Catheter	OD (F / mm)	ID (mm)	Length (mm)	Flow rate* (ml/min)		325 PSI Recommended maximum flow rates (mL/s) Contrast media at 37°C (325 psi = 22.4 bar)**						Implantation technique	Type	Reference	Accessories see page 30/31
						Viscosity 5.8 mPa.s (cP)			Viscosity 11.4 mPa.s (cP)						
						19G	22G	22G	20G	19G	22G				

#### Standard

PUR	5 /1.6	1.1	900	24	10	2	5	6	1	3	5	Seldinger	ST301C	04432096	2
PUR	5 /1.6	1.1	370	24	10	2	5	6	1	3	5	OTW	ST301OTW	04433726	3
PUR	6.5 /2.1	1.4	800	34	11	2	5	7	1	4	6	Seldinger	ST301P	04430441	1
PUR	6.5 /2.1	1.4	800	34	11	2	5	7	1	4	6	Surgical cut-down	T301P	04430387	6
Silicone	6.5 /2.2	1.0	800	26	10	2	6	7	1	4	5	Seldinger	ST301F	04430433	1
Silicone***	6.5 /2.2	1.0	800	26	10	2	6	7	1	4	5	Seldinger	ST311F	04436717	1
Silicone	6.5 /2.2	1.0	800	26	10	2	6	7	1	4	5	Surgical cut-down	T301F	04430000	6
Silicone	8.5 /2.8	1.1	800	28	13	2	6	7	1	4	6	Seldinger	ST301	04430425	1
Silicone***	8.5 /2.8	1.1	800	28	13	2	6	7	1	4	6	Seldinger	ST311	04436709	1
Silicone	8.5 /2.8	1.1	800	28	13	2	6	7	1	4	6	Surgical cut-down	T301	04430018	6
PUR (high flow)	8.5 /2.8	1.6	800	45	12	2	6	8	1	4	7	Seldinger	ST301H	04432460	1
PUR (high flow)	8.5 /2.8	1.6	800	45	12	2	6	8	1	4	7	Surgical cut-down	T301H	04432452	6
PUR (high flow)***	8.5 /2.8	1.6	800	45	12	2	6	8	1	4	7	Seldinger	ST311H	04436814	1
Silicone (high flow)	10 /3.2	1.6	800	47	13	2	6	9	1	4	6	Seldinger	ST301G	04433823	1

#### Small

PUR	5 /1.6	1.1	900	22	10	2	5	7	1	3	5	Seldinger	ST305C	04436962	2
PUR	6.5 /2.1	1.4	800	30	11	2	5	8	1	4	5	Seldinger	ST305P	04436946	1
Silicone	6.5 /2.2	1.0	800	24	10	2	5	8	1	4	6	Seldinger	ST305	04433750	1
Silicone***	6.5 /2.2	1.0	800	24	10	2	5	8	1	4	6	Seldinger	ST315	04436725	1
Silicone	6.5 /2.2	1.0	800	24	10	2	5	8	1	4	6	Surgical cut-down	T305	04436903	6
Silicone	8.5 /2.8	1.1	800	25	10	2	5	8	1	3	6	Seldinger	ST305L	04436920	1
Silicone***	8.5 /2.8	1.1	800	25	10	2	5	8	1	3	6	Seldinger	ST315L	04436710	1
PUR (high flow)	8.5 /2.8	1.6	800	37	12	2	6	9	1	6	6	Seldinger	ST305H	04433556	1

#### Standard

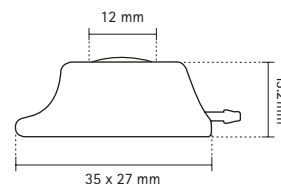

**Material:** Titanium | Polysulphone  
**Weight:** 9g  
**Internal Volume:** 0.5 mL

#### Small

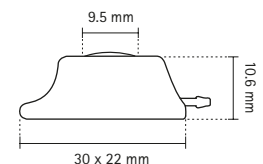

**Material:** Titanium | Polysulphone  
**Weight:** 4.7g  
**Internal Volume:** 0.25 mL

LATEX  
FREE

PVC  
FREE

\* Gravity flow rates established by gravity infusion of NaCl 0.9%, height 1 m. Catheter length 40 cm. According to ISO 10555-1.

\*\* With a catheter of 20 cm and Surecan® Safety II and winged Surecan® 20 G needle. For countries under CE mark only.

\*\*\* With pre-connected catheters.

# Surecan® Safety II

High pressure resistant non-coring needle for long term infusions

Surecan® Safety II is a power-injectable access port needle featuring an easy-to-use safety mechanism that reduces the risk of needlestick injuries. Its small size and innovative design provide comfort for both clinicians and patients, whether in a hospital setting or during home care treatment.



## User safety

An intuitive safety mechanism for reduced risk of needlestick injuries.

## Patient comfort

Low profile and non-absorbant closed-cell foam pad enhances patient comfort.

## Handling

Flexible and ergonomic wings ensures reliable handling.

## Power injections

Suitable for power injections up to 325 psi.

MR-conditional, Latex- and DEHP free

LATEX	PVC	DEHP
FREE	FREE	FREE

## Easy removal

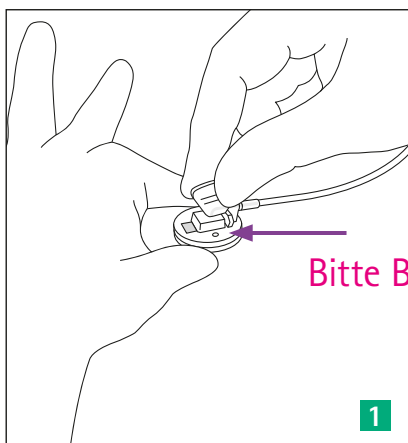

Stabilise the needle base on the port

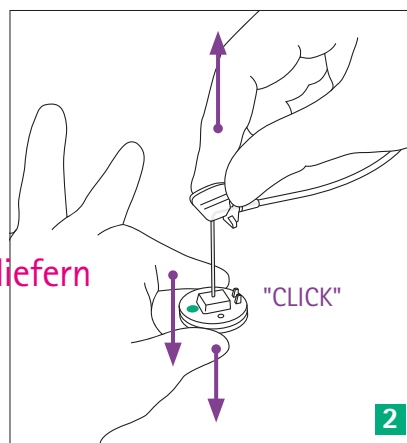

Firmly pull the wings up until you hear a "Click"

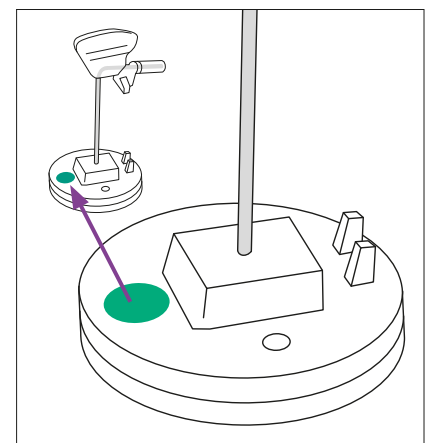

The green dot and audible click clearly indicate the safety mechanism has been activated.



# Surecan® Safety II

High pressure resistant non-coring needle for access ports

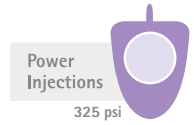

## Surecan® Safety II non-coring safety needle

- Tubing length cannula to connector: 200 mm



Size	Cannula diameter (mm)	Cannula length (mm)	Sales unit (pcs.)	Reference
G 19	1.1	12	20	04447042
G 19	1.1	15	20	04447000
G 19	1.1	20	20	04447001
G 19	1.1	25	20	04447002
G 19	1.1	32	20	04447003
G 19	1.1	38	20	04447004
G 20	0.9	12	20	04447043
G 20	0.9	15	20	04447005
G 20	0.9	20	20	04447006
G 20	0.9	25	20	04447007
G 20	0.9	32	20	04447008
G 20	0.9	38	20	04447009
G 22	0.7	12	20	04447044
G 22	0.7	15	20	04447010
G 22	0.7	20	20	04447011
G 22	0.7	25	20	04447012
G 22	0.7	32	20	04447013

## Surecan® Safety II non-coring safety needle with pre-connected Caresite® and Y-site

- Y-site configuration
- Tubing length Y-site to connector: 98 mm
- Tubing length cannula to Y-site: 105 mm
- Caresite® is a needle-free, positive pressure valve which reduces the risk of blood reflux



Size	Cannula diameter (mm)	Cannula length (mm)	Sales unit (pcs.)	Reference
G 19	1.1	12	20	04447057
G 19	1.1	15	20	04447045
G 19	1.1	20	20	04447046
G 19	1.1	25	20	04447047
G 19	1.1	32	20	04447048
G 19	1.1	38	20	04447049
G 20	0.9	12	20	04447058
G 20	0.9	15	20	04447050
G 20	0.9	20	20	04447051
G 20	0.9	25	20	04447052
G 20	0.9	32	20	04447053
G 22	0.7	12	20	04447059
G 22	0.7	15	20	04447054
G 22	0.7	20	20	04447055
G 22	0.7	25	20	04447056

# Winged Surecan®

## Access port needles

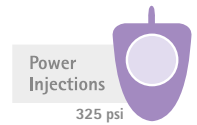

### Winged Surecan® non-coring needle

- Use for long-term infusions
- High pressure resistant up to 325 psi (22.4 bar)
- Flexible wings for easier puncture and fixation
- Latex- and DEHP-free
- Extension tubing with clamp
- Tubing length cannula to connector: 200 mm



Size	Cannula diameter (mm)	Cannula length (mm)	Sales unit-pcs.	Reference
19G	1.1	15	15	04448286
19G	1.1	20	15	04448294
19G	1.1	25	15	04448308
20G	0.9	15	15	04448332
20G	0.9	20	15	04448340
20G	0.9	25	15	04448359
20G	0.9	30	15	04448367
22G	0.7	12	15	04448375
22G	0.7	15	15	04448383
22G	0.7	20	15	04448391
22G	0.7	25	15	04448405

### Winged Surecan® non-coring needle with Y-site

- Use for long-term infusions
- Flexible wings for easier puncture and fixation
- Latex- and DEHP-free
- Tubing length Y-site to connector: 98 mm
- Tubing length cannula to Y-site: 105 mm
- Y-site configuration



Size	Cannula diameter (mm)	Cannula length (mm)	Sales unit-pcs.	Reference
19G	1.1	20	15	04448430
19G	1.1	25	15	04448448
20G	0.9	15	15	04448472
20G	0.9	20	15	04448480
20G	0.9	25	15	04448499
22G	0.7	15	15	04448529
22G	0.7	20	15	04448537
22G	0.7	25	15	04448545
22G	0.7	30	15	04448553

# Celsite® Access Port Systems

## Portfolio overview and type declaration

Indication	Catheter	OD	Catheter material	Access Port type	Dead volume port	Dead volume catheter (mL/cm)
Venous	Small catheters	5 F	Polyurethane	ST201C	0.50 mL	0.010 mL
				ST301C, ST301OTW		
				ST305C	0.25 mL	
				4430263, 4438604	0.33 mL	
				4438647	0.15 mL	
				SST605C	0.30 mL	
	6.5 F	Polyurethane	ST201P, T301P, ST301P	0.50 mL	0.015 mL	
			ST305P, STL205P, STR205P	0.25 mL		
			T601P, SST601P	0.50 mL		
	6.5 F	Silicone	SST605P	0.30 mL	0.008 mL	
			T201F, ST201F, T301F, ST301F, ST311F*, ST201F ECG	0.50 mL		
			T205, ST205, ST215*, T305, ST305, ST315*	0.25 mL		
	Large and high flow catheters	8.5 F	Silicone	T601F, SST601F	0.50 mL	0.009 mL
				T605F, SST605F	0.30 mL	
				T201, ST201, T301, ST301, ST311*, STL201L, STR201L	0.50 mL	
		8.5 F	Silicone	ST305L	0.25 mL	0.011 mL
				T601L, SST601L	0.5 mL	
				SST605L	0.3 mL	
8.5 F		Polyurethane	ST201H, T301H, ST301H, ST311H*, STL201H, STR201H	0.50 mL	0.020 mL	
			ST305H	0.25 mL		
			T601H, SST601H	0.50 mL		
10 F	Silicone	SST605H	0.3 mL	0.020 mL		
		ST201G, ST301G	0.50 mL			
		SST601G	0.50 mL			
Speciality venous	Small catheters	4.5 F	Polyurethane	Babyport®	0.15 mL	0.005 mL
		5 F	Polyurethane	Brachial	0.15 mL	0.010 mL
		6 F	Silicone	Babyport® S	0.15 mL	0.011 mL
		6.5 F	Silicone	STR205F, STL205F, ST205F ECG	0.25 mL	0.008 mL
	Large and high flow catheters	8.5 F	Silicone	STR201L, STL201L, ST201 ECG	0.50 mL	0.010 mL
				ST205ECG	0.25 mL	

\* Pre-connected Access Port Systems

### Type Declaration:

Accessories	Exit Cannula Orientation	Housing Material / Suture Holes	Connection	Indication	Catheter	Technique
SST = Safety Seldinger Equipment ST = Seldinger Equipment T = Surgical Cut-Down	R = right cannula exit L = left cannula exit	2 = Epoxy housing 3 = PSU housing w. empty suture holes 4 = Epoxy Double housing 5 = PSU housing w. Silicone suture areas 6 = PEEK housing w. suture holes 7 = PEEK housing with silicone plugs	0 = w. separate connection rings 1 = pre connected	1= Venous (std) 2= Venous (small)	C = PUR; 5F F = Si; 6.5F L = Si; 8.5F P = PUR; 6.5F H = PUR; 8.5F G = Si; 10F	OTW = Over the Wire ECG = ECG implantation technique

# Accessories

## Venous accessories

Pieces	Kit designation	Implantation technique	Percutaneous		
			Seldinger	OTW	Seldinger
			Kit 1	Kit 3	Kit 2
2	A	Straight Surecan® needles	22 G x 30 mm	22 G x 30 mm	22 G x 30 mm
1	B	Vein lifter	x	x	x
1	C	Puncture needle	18 G x 70 mm	18 G x 70 mm	18 G x 70 mm
1	E	J guide wire with dispenser	0.035" x 50 cm	0.035" x 70 cm	0.035" x 50 cm
1	F	Dilator		6F x 100 mm	
1	G	Tear-away introducer	L 180/140 mm		L 180/140 mm
1	H	Tunnelling rod	x	x	x
1	I	Omnifix luer syringe	10 mL	10 mL	10 mL
1	J	Winged Surecan® needle	20 G x 20 mm	20 G x 20 mm	20 G x 20 mm

Ultra sound cover und sicherheitsnadeln im Bild einfügen und neu nummerieren

Bitte Abb. liefern

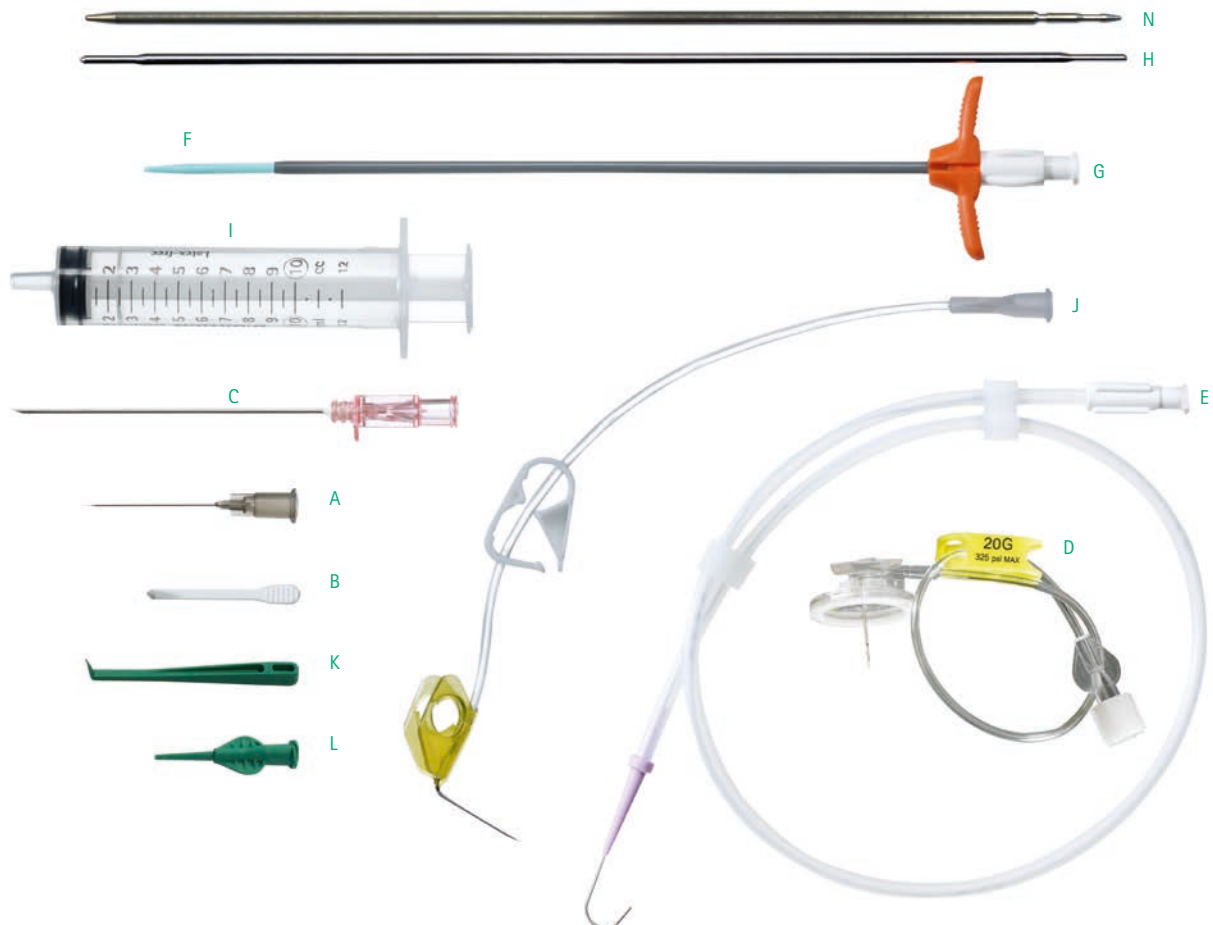

# Accessories

## Venous accessories

		Implantation technique	Percutaneous				
			Seldinger	Seldinger	OTW	Seldinger	
Pieces		Kit designation	Kit 1	Kit 2	Kit 3	Kit 4 (Baby)	Kit 5 (Baby)
2	A	Straight Surecan® needles	22 G x 30 mm	22 G x 30 mm	22 G x 30 mm	22 G x 30 mm	22 G x 30 mm
1	B	Vein lifter	x	x	x	x	x
1	C	Puncture needle	18 G x 70 mm	18 G x 70 mm	18 G x 70 mm	20 G x 50 mm	18 G x 70 mm
1	E	J guide wire with dispenser	0.035" x 50 cm	0.035" x 50 cm	0.035" x 70 cm	0.025" x 50 cm	0.035" x 50 cm
1	F	Dilator			6F x 100 mm		
1	G	Tear-away introducer	L 180/140 mm	L 180/140 mm		L 80/50 mm	L 180/140 mm
1	H	Tunnelling rod	x	x	x	x	x
1	I	Omnifix luer syringe	10 mL	10 mL	10 mL	10 mL	10 mL
1	J	Winged Surecan® needle	20 G x 20 mm	20 G x 20 mm	20 G x 20 mm	22 G x 15 mm	22 G x 15 mm

# Accessories

## Venous accessories

		Implantation technique	Surgical Cut-down		Percutaneous			
				ECG	OTW	Seldinger		ECG
Pieces		Kit designation	Kit 6	Kit 14	Kit 10 (Brachial)	Kit 4 (Baby)	Kit 5 (Baby)	Kit 9
2	A	Straight Surecan® needles	22 G x 30 mm	22 G x 30 mm	22 G x 30 mm	22 G x 30 mm	22 G x 30 mm	22 G x 30 mm
1	B	Vein lifter	x	x	x	x	x	x
1	C	Puncture needle			18 G x 70 mm	20 G x 50 mm	18 G x 70 mm	18 G x 70 mm
1		Introcan needle				20 G x 32 mm		
1	E	J guide wire with dispenser		0.035" x 70 cm	0.035" x 150 cm	0.025" x 50 cm	0.035" x 50 cm	0.035" x 70 cm
1	F	ECG cable		x				x
1	G	Tear-away introducer/ Dilator			L 180/140 mm	L 80/50 mm	L 180/140 mm	180/140 mm
1	H	Tunnelling rod			x	x	x	x
1	I	Omnifix luer syringe		10 mL	10 mL	10 mL	10 mL	10 mL
1	J	Winged Surecan® needle			22 G x 15 mm	22 G x 15 mm	22 G x 15 mm	20 G x 20 mm

## Separate accessory kits

		Reference	04430483	04430484	04430492
Pieces		Kit designation	AP 6F	AP 7F	AP 9F
1	C	Puncture needle	20 G x 50 mm	18 G x 70 mm	18 G x 70 mm
1		Introcan needle	20 G x 32 mm		
1	E	J guide wire with dispenser	0.025" x 50 cm	0.035" x 50 cm	0.035" x 50 cm
1	G	Tear-away introducer/ Dilator	6F, short (80/50 mm)	7F x180/140 mm	9F x180/140 mm
1	H	Tunnelling rod	x	x	x
1	B	Vein lifter	x	x	x
1	I	Omnifix luer syringe	10 mL	10 mL	10 mL
1	J	Winged Surecan® needle	22 G x 15 mm	20 G x 20 mm	20 G x 20 mm

# Customized Access Port Kits

Individual complete solution for port implantations



**Customized Access Port Kits combine a sterile Access Port with individual components in one pouch for standardized procedures.**

**This all-in-one approach offers several benefits:**

- Simplifies and shortens preparation time for more efficient port implantation.\*
- Reduces packaging waste in hospitals and facilitates storage.
- Includes safety components designed to minimize the risk of needlestick injuries, in compliance with EU directive 2010/32/EC.
- Leverages B. Braun's extensive experience and commitment to quality as a kit provider for customized solutions.

Analyse processes -  
finding solutions

\* Data on file at B. Braun

# Standard Access Port Kits

The Celsite<sup>®</sup>, Surecan<sup>®</sup> and Safecan<sup>™</sup> family

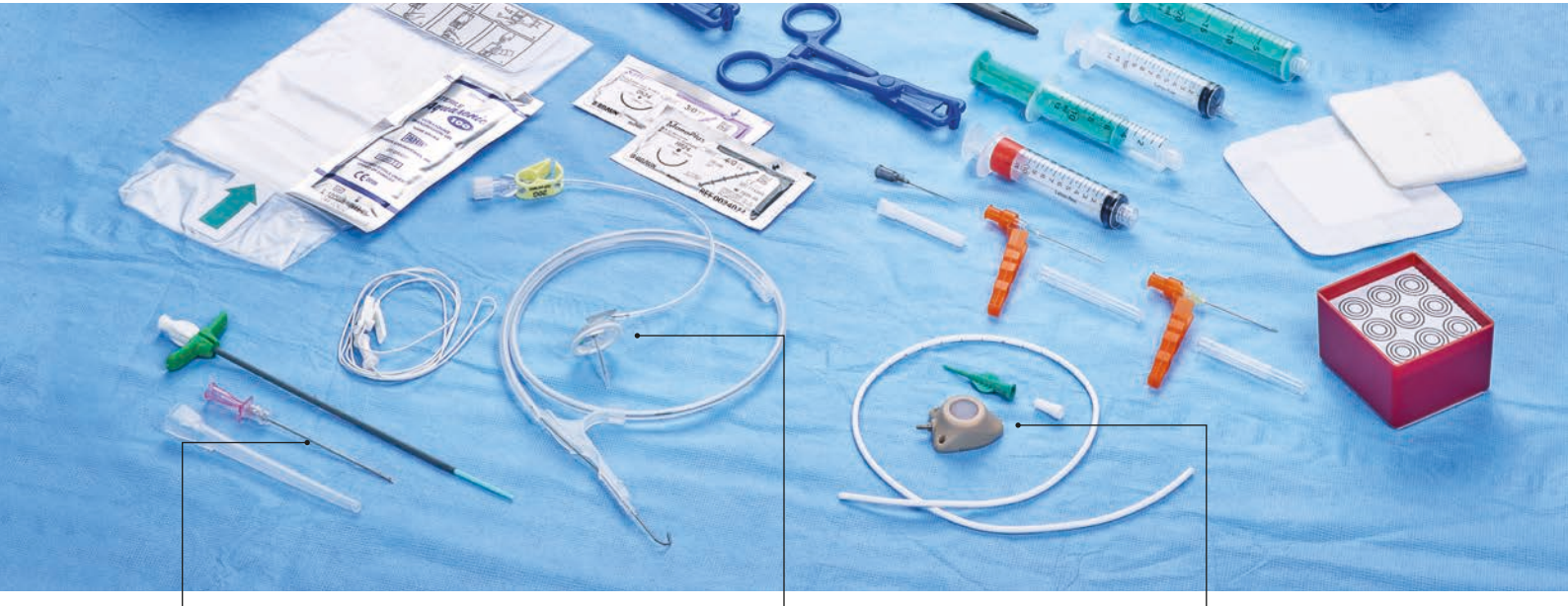

## Safecan<sup>™</sup> Safety - Safety Puncture Needle

- Safety mechanism reduces the risk of needlestick injuries.
- Echogenic puncture needle for needle tip location via ultrasound.



## Surecan<sup>®</sup> Safety II - Safety Port Needle

- Intuitive safety mechanism reduces the risk of needlestick injuries.
- High pressure resistance up to 325 psi.



## Celsite<sup>®</sup> Safety - Venous Access Ports without any compromise on safety

- PEEK material (Polyetheretherketone) for high chemical resistance and excellent durability.
- Extra large septum diameter for easy puncturing.
- Titanium bottom plate for high puncture resistance .
- Anatomic design with a low profiled nose simplifies the insertion and allows the creation of a small port pocket.

In compliance with EU directive 2010/32/EC



# Standard Access Port Kits

Totally equipped solution

The Standard Access Port Kits offer an entire solution for the Access Port implantation with a single sterile packed Access Port and standard accessories included.

Reference	Type	Port description	Implantation technique
5400005	Complete Seldinger Kit T605F	Celsite® Safety Small 6.5 F silicone catheter	Seldinger
5400010	Complete Seldinger Kit T601H	Celsite® Safety Standard 8,5 F polyurethane catheter	Seldinger
5400015	Complete Surgical Kit T601F	Celsite® Safety Standard 6.5 F silicone catheter	Surgical cut-down

The following accessories are included in the Standard Access Port Kit configurations:

## Skin disinfection

- 1 SUSI® sponge forceps, 200 mm
- 5 Gauze swabs, plum size

## Cover

- 1 Cover drape, 148 x 240 cm
- 1 Cover drape, 173 x 180 cm
- 2 Cover drapes sidewise, 75 x 100 cm
- 1 Cover drape, 150 x 170 cm
- 1 Cover drape transparent, adhesive 110 x 120 cm
- 1 Cover drape, 140 x 150 cm (packaging drape)

## Compresses and swabs

- 30 Gauze compresses with x-ray strips, 12-ply, 10 x 10 cm
- 5 Gauze swabs, plum size with x-ray strips
- 2 Askina® PAD S compresses with slit, 7.5 x 7.5 cm

## Bowls and syringes

- 1 Bowl 250 ml, transparent
- 2 Bowls 500 ml, blue
- 1 3-Pocket tray, 24 x 25 x 5 cm, blue
- 2 Syringes Omnifix® 20 ml, Luer Lock
- 2 Syringes Omnifix® 10 ml, Luer Lock
- 2 Syringes Injekt 20 ml, Luer Slip

## Scapels and needles

- 1 Safety scalpel Fig. 11
- 1 Safety scalpel Fig. 15
- 1 Hypodermic Needle Pro® 0.6 x 38 mm, 23 G
- 1 Hypodermic Needle Pro® 0.9 x 38 mm, 20 G
- 1 Surecan® Safety II port needle 20 G x 20 mm
- 1 Needle collector box

## Sutures and wound dressing

- 1 Novosyn® uncolored 3/0 (2) 45 cm, DS19 (M)
- 1 Monoplus® violet 4/0 (1,5) 70 cm, HR26 (M)
- 1 Askina® strips, 12 x 102 mm (1 piece = 6 strips)
- 1 Askina® Soft patch, 9 x 10 cm

## Miscellaneous

- 2 Coats, size XL
- 2 Universal clamps (model Kiel)
- 1 Table bag, 80 x 144 cm
- 1 Lamp cover
- 1 Suction bag

## Further Seldinger equipment







- 1 Safety puncture needle, 18 G x 70 mm, echogenic \*
- 1 Intradyn® peelable introducer, 7 F / 9 F \*
- 1 Guidewire J3, 50 cm, 0.035", marked each 10 cm \*
- 1 Tunneling rod \*

\* not included in surgical cut-down Standard Access Port Kits

# Customized Access Port Kits

## Access port portfolio

Wide range of silicone and PUR catheters as well as two different port sizes, standard and small, for the configuration of your individual Access Port Kit. Choose additionally out of more than 3000 accessories for a customer-adapted creation.

	Catheter	OD (F/mm)	ID (mm)	Length (mm)	Flow rate* (ml/min)		325 PSI Recommended maximum flow rates (mL/s) Contrast media at 37°C (325 psi = 22.4 bar)**			Type	Reference
					19 G	22 G	Viscosity up to 11.4 mPa.s (cP)				
							22 G	20 G	19 G		
<b>Celsite® Safety Standard</b>											
	Silicone	6.5 / 2.2	1.1	500	26	10	2	5	5	T601F	4437556K
	Silicone	8.5 / 2.8	1.2	500	34	11	2	5	5	T601L	4437573K
	PUR	6.5 / 2.1	1.4	500	37	12	2	5	5	T601P	4437565K
	PUR	8.5 / 2.8	1.6	500	48	12	2	5	5	T601H	4437581K
<b>Celsite® Safety Small</b>											
	Silicone	6.5 / 2.2	1.1	500	26	10	2	5	5	T605F	4437758K
	Silicone	8.5 / 2.8	1.2	500	34	11	2	5	5	T605L	4437780K
	PUR	6.5 / 2.1	1.4	500	37	12	2	5	5	T605P	4437768K
	PUR	8.5 / 2.8	1.6	500	48	12	2	5	5	T605H	4437773K
<b>Celsite® PSU Standard</b>											
	Silicone	6.5 / 2.2	1.0	800	26	10	2	6	8	T301F	04430000K
	Silicone	8.5 / 2.8	1.1	800	28	13	2	6	9	T301	04430018K
	PUR	8.5 / 2.8	1.6	800	45	12	2	7	9	T301H	04432452K
<b>Celsite® PSU Small</b>											
	Silicone	6.5 / 2.2	1.0	800	24	10	2	5	6	T305	04436903K
<b>Celsite® Epoxy Standard</b>											
	Silicone	6.5 / 2.2	1.1	800	26	10	2	6	8	T201F	04430034K
	Silicone	8.5 / 2.8	1.1	800	28	13	2	6	9	T201	04430026K
<b>Celsite® Epoxy Small</b>											
	Silicone	6.5 / 2.2	1.0	800	24	10	2	5	6	T205	04430085K

PVC FREE	LATEX FREE	DEHP FREE
-------------	---------------	--------------

\* Gravity infusion of saline (0.9%) through a 22G respectively 19G needle from a height difference of 1 m and a catheter length of 40 cm. According to ISO10555-1

\*\* Flow rates determined according to ISO 10555-6 with a catheter of 20 cm and Surecan® Safety II 20 mm needle

# Premium Solution Concepts

Various options

Using B. Braun Premium Solution Concepts means to design Customized Access Port Kits for implantation procedures. Components can be added or removed to create your individual and complete solution.



Please contact your B. Braun consultant for your individual Access Port Kit or send an email to [vascular.systems@bbraun.com](mailto:vascular.systems@bbraun.com).

Distributor

B. Braun Melsungen AG | Vascular Systems | Sieversufer 8 | 12359 Berlin | Germany  
Phone +49 30 568 207-300 | Fax +49 30 568 207-130 | [www.bbraun.com](http://www.bbraun.com)

Manufacturer acc. to MDD 93/42

B. Braun Médical | 26, rue Armengaud | 92210 Saint-Cloud | France  
Tél +33 (0) 1 41 10 53 00 | Fax +33 (0) 1 41 10 53 99 | [www.bbraun.fr](http://www.bbraun.fr)

The main product trademark 'Aesculap' is a registered trademark of Aesculap AG. The product trademarks „Celsite“, „Surecan“ and „Cytocan“ are registered trademarks of B. Braun Melsungen AG.

Subject to technical changes. All rights reserved. This brochure may only be used for the exclusive purpose of obtaining information about our products. Reproduction in any form partial or otherwise is not permitted.