

Plasmat[®] Futura Apheresis Machine

Instructions for Use SW 3.0xEN



H.eparin induced
E.xtracorporeal
L.DL
P.recipitation

B | BRAUN
SHARING EXPERTISE

CE 0123

CE marking according to directive 93/42/EEC.

Technical alterations reserved.

38910344EN / Rev. 3.10.00 / 11.2014

B | BRAUN
SHARING EXPERTISE

B. Braun Avitum AG

Schwarzenberger Weg 73-79
34212 Melsungen, Germany
Tel +49 (56 61) 71-0
Fax +49 (56 61) 75-0

www.bbraun.com

1	Safe Handling	1
2	Product Description	2
3	Installation and Commissioning	3
4	Preparing the Machine for Operation	4
5	Priming and Rinsing	5
6	Therapy	6
7	Reinfusion and Termination	7
8	Disinfection	8
9	Troubleshooting	9
10	Options and Accessories	10
11	Technical Data	11

Table of contents

1	Safe Handling	7
1.1	About these Instructions for Use.....	7
1.1.1	Terminology	7
1.1.2	Validity	9
1.1.3	Target Group	9
1.1.4	Warnings, Notices and Symbols in these Instructions for Use	9
1.1.5	Information and Activities	10
1.2	Intended Use and Indication	11
1.3	Contraindication	12
1.4	Side Effects.....	12
1.5	Special Hazards and Precautions.....	12
1.5.1	Special Patient Conditions	12
1.5.2	Electrical Hazards	13
1.5.3	Electromagnetic Interactions	14
1.5.4	Precautions for Treatment	15
1.6	Information for the Responsible Organization.....	18
1.6.1	Training by Manufacturer prior to Commissioning.....	18
1.6.2	Requirements on the User	18
1.6.3	Conformity	18
1.6.4	Manufacturer's Responsibility	19
1.6.5	Modifications of the Machine	19
1.6.6	Preventive Maintenance and Technical Safety Inspection	19
1.6.7	Expected Service Life	20
1.6.8	Technical Changes	20
1.7	Disposal	20
1.7.1	Disposal of Waste Products	20
1.7.2	Taking Back of Old Machines	20

1 Safe Handling

1.1 About these Instructions for Use

These instructions for use form an integral part of the machine. They describe the appropriate and safe use of the machine.

NOTICE!

The machine must always be used in accordance with the instructions for use. Only then the manufacturer will consider himself liable for any effect on safety, reliability and performance of the machine.

Always keep the instructions for use at the machine for later use.
Pass on the instructions for use to any future user of the machine.



Also observe instructions for use of consumables!

Installation/deinstallation and servicing of the machine are only to be performed by technicians authorized by the manufacturer. Therefore, this information is not part of these instructions for use but is contained in the separate service manual.

1.1.1 Terminology

General Terminology

The following general terminology is used in these instructions for use:

Term	Definition
IFU	Instructions for use
Responsible organization	Person or organization which uses a medical device for commercial purposes or provides third parties and other users with machines taking all legal responsibilities for the product and safety of the patients and users.
User	Member of the medical staff trained and authorized for using the Plasmat® Futura.
Technician	Person who is responsible for installation, repair and maintenance of active medical devices within B. Braun Avitum AG. The technician must be trained and authorized for work on the concerning machine.
Physician	Medical practitioner with a professional medical degree authorized by the responsible organization to treat the patient.

Application-Specific Terminology

The following application-specific terminology is used in these instructions for use:

Term	Definition
Apheresis machine	Plasmat® Futura machine
Apheresis	Extracorporeal blood and/or plasma therapy
Extracorporeal therapy	Medical procedure performed outside the body
H.E.L.P.	H eparin induced E xtracorporeal L DL P recipitation A plasmapheresis method.
Plasmapheresis	Removal, treatment and return of blood and plasma from blood circulation.
Applied part	Extracorporeal circuit and all parts permanently and conductively connected to it. For the Plasmat® Futura, these are the tubing system (e.g. lines, filters, bags) and all machine parts which are connected to the tubing system and which can be touched by the user and patient during therapy.

Abbreviations

BLD	Blood leak detector
BP	Blood pump
DAD	Dialysate air detector
DP	Dialysate pump
H	Plate warmer
HAK	Heparin adsorber clamp
HP	Heparin pump
LC	Load cell
PA	Arterial pressure
PBE	Prefilter pressure (blood side entry pressure)
PBP	Plasma/buffer pump
PDF	Dialyzer pressure
PDI	Dialysate inlet pressure
PDPA	Precipitate filter/adsorber pressure drop
PPF	Precipitate filter pressure

PPL	Plasma pressure
PV	Venous pressure
SAD	Safety air detector
SAK	Tubing clamp
TMP	Transmembrane pressure
UFP	Ultrafiltration pump

1.1.2 Validity

Article Numbers

These instructions for use apply to Plasmat® Futura machines with the following article numbers (REF):

- 7062100
- 706210A (110V/120V)

Software Version

These instructions for use apply to software version SW 3.0x (x = any).

The software version installed at the machine can be displayed in the *SETTINGS* screen.

Software updates must be performed by service technicians only!

1.1.3 Target Group

The target group for these instructions for use is specialist medical staff.

The H.E.L.P. apheresis should be applied and supervised only by physicians with sufficient experience in the execution of extracorporeal procedures for blood purification.

The Plasmat® Futura may only be used by persons instructed for its appropriate operation.

1.1.4 Warnings, Notices and Symbols in these Instructions for Use

Three signal words DANGER, WARNING and CAUTION in this document point out particular hazardous situations for users and patients. They also suggest measures that shall be taken in order to avoid the respective hazardous situation.

The signal word NOTICE points out measures related to prevention of damage.

Signal Word	Definition
DANGER	Indicates an imminently hazardous situation which, if not avoided, will result in death or serious injury.
WARNING	Indicates a potentially hazardous situation which, if not avoided, could result in death or serious injury.

CAUTION	Indicates a hazardous situation which, if not avoided, could result in minor or moderate injury.
NOTICE	Used to address practices not related to personal injury.

DANGER!

Here, type and source of hazardous situation are listed and possible consequences if measures are not followed!

- This is the list of measures to prevent the hazard.
-

WARNING!

Here, type and source of hazardous situation are listed and possible consequences if measures are not followed!

- This is the list of measures to prevent the hazard.
-

CAUTION!

Here, type and source of hazardous situation are listed and possible consequences if measures are not followed!

- This is the list of measures to prevent the hazard.
-

NOTICE!

Information directly or indirectly related to prevention of damage.

1.1.5 Information and Activities

Information



This is additional useful information concerning procedures, background information and recommendations.

Activities

1. In this way instructions for an activity are listed.

 This symbol marks the result of an activity.

1.2 Intended Use and Indication

The Plasmat[®] Futura is intended for implementing and monitoring extracorporeal treatments of plasma. The machine can be used for patient treatment in a hospital and health center when prescribed by a physician.

NOTICE!

The Plasmat[®] Futura may only be used in combination with the H.E.L.P. apheresis treatment system from B. Braun Avitum AG. Refer also to the instructions for use for the H.E.L.P. apheresis treatment system.

The Plasmat[®] Futura is used in connection with the H.E.L.P. apheresis treatment unit for the therapeutic removal of LDL- and VLDL-cholesterol, lipoprotein(a) and fibrinogen from plasma. The H.E.L.P. apheresis is indicated in the case of:

- Patients with severe lipid metabolism disorders that cannot be adequately controlled by diet and drugs including:
 - homozygous familial hypercholesterolemia,
 - heterozygous familial hypercholesterolemia or secondary hypercholesterolemia where the plasma LDL cholesterol concentration cannot be adequately controlled despite maximum dietary and drug therapy, high risk of arteriosclerotic complications or manifest coronary artery disease (CAD),
 - greatly elevated plasma lipoprotein(a) concentrations (> 60 mg/dl) and a high risk of arteriosclerotic complications or manifest (CAD).
Dietary and lipid lowering drug treatments should be continued for optimum results from H.E.L.P. apheresis therapy.
- Patients with sudden hearing loss (hearing loss \geq 15 dB in 3 frequency bands in the affected ear relative to the unaffected ear) if treatment is started within a maximum of 6 weeks after the occurrence of the event.
- Patients with acute hyperlipidemia or fibrinogenemia in whom acute and effective reduction of fibrinogen, LDL cholesterol, VLDL cholesterol or lipoprotein(a) is medically indicated.
- Patients suffering from diseases caused and promoted by disturbed blood flow for whom improvement of circulation is medically indicated by means of alteration of blood composition through extracorporeal treatment.

This treatment should be administered only after careful individualized benefit-risk assessment.

1.3 Contraindication

H.E.L.P. apheresis treatment should not be performed in:

- patients with hemorrhagic diathesis or clotting disorders in whom there is an increased bleeding risk because of the need for anticoagulation
- patients with suspected occult hemorrhage, e.g., ulcers in the gastrointestinal tract
- patients with acute hepatic disorders, advanced liver cirrhosis or hepatic insufficiency
- patients with acute or severe chronic heart disease not amenable to exposure to an extracorporeal apheresis procedure
- patients with acute cerebrovascular disease, as long as cerebral hemorrhage has not been excluded
- patients with acute renal failure
- patients with known hypersensitivity to heparin
- patients with pronounced allergic conditions and hypersensitivity to any of the materials used in the extracorporeal circulation
- any patient whose physical constitution or development does not allow to tolerate extracorporeal treatment.

1.4 Side Effects

Patients may experience the following side effects:

- Cardiovascular system: anginal pain, hypertension, hypotension, cardiac arrhythmias, vasovagal reactions
- Blood clotting: coagulation disorders, hemolysis
- Hematology: anemia (e.g., iron deficiency anemia during long-term treatment)
- Hypersensitivity (e.g., nausea, feeling hot, pruritus, dyspnea, rash, burning eyes); patients who are sensitive to acetate may experience facial flushing, hypotension, nausea, abdominal pain
- CNS: headache, fatigue/exhaustion, dizziness
- Other: pallor, feeling warm, sweating, sensation of tension in the limbs
- Hypertension and edema in patients with renal failure

1.5 Special Hazards and Precautions

1.5.1 Special Patient Conditions

The physician in charge of the treatment is responsible for choosing the suitable therapy, based on medical and analytical findings and the general health and condition of the patient.

In the following patient populations, H.E.L.P. apheresis should only be used with particular caution and only after weighing potential risks:

- pregnant women and nursing mothers
- children and infants in whose case the extracorporeal volume is a limiting factor.

Particularly careful benefit-risk assessment is required in patients with C1 esterase inactivator deficiency or hereditary C3 deficiency before performing H.E.L.P. apheresis.

⚠ WARNING!

Risk to patient when using protamin chloride/sulphate to neutralize heparin.

- These substances should only be administered to reverse the heparin effect in the case of life-threatening hemorrhage.
- Protamin chloride/sulphate should be considered as an emergency measure, according to the instructions of manufacturer.

⚠ CAUTION!

Risk to patient due to elimination of parallel medication to differing extents! The level of active substances in a patient receiving H.E.L.P. treatment can be lowered up to 60 %.

- If possible, any regularly prescribed medication should be taken after the H.E.L.P. treatment.

1.5.2 Electrical Hazards

Connection to and Disconnection from Mains Supply

The machine contains life-threatening electrical high voltages.

⚠ WARNING!

Risk of electric shock and fire!

- Always insert mains plug completely into the mains socket.
- Always pull/push on the plug not on the mains cord to connect or disconnect the mains plug.
- Avoid damage of the mains cord, e.g. due to running over it with the machine casters.
- Complete disconnection from the mains supply results only if the mains plug is removed completely from the mains socket. If the power switch is switched off the machine is not completely disconnected!

The machine shall not be used or connected to mains supply if the housing or the mains cord is damaged in any way. A damaged machine must be submitted for repairs or disposed of.

Switching off the mains switch will not isolate the mains voltage from all internal parts of the machine (e.g. mains filter, mains switch). To disconnect the complete machine from the mains always remove the mains plug from the mains socket!

Grounding Reliability

Grounding reliability can only be achieved when the machine is connected to an equivalent receptacle of the electrical installation of the premises (see section 3.4.2 Electrical Connection (53)). The ground connection shall be maintained reliably to protect the patient and medical staff.

WARNING!

Risk of electric shock if machine is not properly grounded!

- The machine must be connected to a mains supply with protective earth.

Interaction with other Devices

The machine shall be connected to a separate mains wall socket. When using the Plasmat® Futura in combination with other therapeutic devices, it is recommended to use a connection line for electrical ground, since the leakage currents from all connected devices are additive and an electrostatic discharge from the environment to the machine may occur. A special potential equalization cable is available. It can be connected to the bolt at the rear side of the machine. The ambient conditions of the premises must be in accordance to the local requirements (see technical data).

WARNING!

Risk to patient due to leakage currents when using the machine in combination with other therapeutic devices of protection class I.

- Connect electrical potential equalization also to every other therapeutic device.

Do not connect customary consumer devices to the same mains socket as the Plasmat® Futura and do not connect them in parallel.

1.5.3 Electromagnetic Interactions

The Plasmat® Futura machine has been developed and tested in accordance with the valid standards for interference suppression and electromagnetic compatibility (EMC). However, it cannot be guaranteed that no electromagnetic interaction with other devices will occur (examples: mobile phones, computer tomograph (CT)).

CAUTION!

Risk of electrostatic discharge from other devices!

- It is recommended that mobile phones and other devices emitting strong electromagnetic radiation only be used at a minimum distance, according to IEC 60601-1-2 (see technical data).

NOTICE!

Placing other therapeutic or diagnostic medical devices on the machine or near by or use of non-medical devices directly near the machine can influence electromagnetic interactions. In this case the user must observe the Plasmat® Futura and all other machines to assure their correct operation.

1.5.4 Precautions for Treatment

⚠ CAUTION!

Risk to patient due to thrombosis or bleeding!

Systemic and continuous anticoagulation values must be calculated to avoid either thrombosis or bleeding.

- Determine blood clotting parameters before, during and after treatment in order to estimate suitable anticoagulation values. Bed-side measurement with quality controlled devices is recommended.
 - Take in mind that anticoagulation values from whole blood samples can differ from those of plasma samples.
-
- H.E.L.P. apheresis should only be applied and supervised by physicians with adequate experience in extracorporeal blood purification techniques.
 - H.E.L.P. apheresis should only be performed by persons instructed for its appropriate application.
 - Systemic and continuous anticoagulation must be adjusted and blood clotting be closely monitored by an appropriate method before, during and after the therapy.
 - Heparin treatment of plasma during H.E.L.P. apheresis reduces the concentrations of fibrinogen, antithrombin III, plasminogen, and a number of plasma proteins including C3-C4 complement and C1 inhibitor. This has no adverse clinical consequences because of the short regeneration times.
 - In patients with low initial fibrinogen levels, the treated plasma volume should be reduced so that the fibrinogen concentration does not fall below the level of 60 mg/dl.

Handling of Components

- The components of the H.E.L.P. Futura treatment set are intended for single use only. Do not re-use. The re-use of single-use devices creates a potential risk of patient or user. It may lead to contamination and/or impairment of functional capability. Contamination and/or limited functionality of the device may lead to injury, illness or death of the patient.
- The components of the H.E.L.P. Futura treatment set should be stored at the storage temperature stated on the respective package.
- The components of the H.E.L.P. Futura treatment set should not be used beyond the expiration date stated on the components and the outer packaging.
- Components of the H.E.L.P. Futura treatment set should not be used if the sterile packaging, individual components or connectors are damaged.
- Do not remove the sterile packaging until immediately before use.
- Use components immediately after removing protective caps.
- The arrows indicating the direction of flow on the components of the H.E.L.P. Futura treatment set must be followed.
- Solutions of the H.E.L.P. Futura treatment sets should be kept out of the reach of children.
- H.E.L.P. solutions are not intended for intravenous infusion.
- H.E.L.P. solutions must not be used unless they are clear and colorless.
- The H.E.L.P. BicEL solution should only be used after mixing the bicarbonate and electrolyte concentrates.
- The ready-to-use BicEL solution should be used immediately after mixing. If not, the user is responsible for use of the solution within 24 hours.
- If an individual component (filter, heparin adsorber) needs to be replaced, it should be separately primed and rinsed with at least 2,000 ml of normal saline solution (0.9 % NaCl) prior to integration into the H.E.L.P. Futura treatment set unless described otherwise in the instructions for that particular component. The replacement procedure is described in these instructions for use. Inappropriate or inadequate component preparation may lead to hemolysis and/or allergic reactions.

Before Treatment

- All patients should have the blood clotting parameters determined before the start of treatment to enable coagulation monitoring: i.e. activated partial thromboplastin time (PTT), activated clotting time (ACT), prothrombin time (PT), international normalized ratio (INR) and fibrinogen.
- The entire H.E.L.P. Futura set, i.e., all plasma carrying filters and lines, must be primed and rinsed with a total of $\geq 2,400$ ml of heparinized normal saline solution (0.9 % NaCl) before the start of treatment, as described in these instructions for use, in order to avoid hemolysis and/or intolerance reactions, such as a rise in body temperature, shivering, chills, burning eyes, and itching.

During Treatment

- In case of malfunction, the therapy must be interrupted immediately (usually, the machine will do this automatically and switch to therapy bypass), and the cause should be identified and corrected.
- To avoid hemolysis, the blood flow rate should be a maximum of 40 ml/min after connecting the patient to the blood lines. Then gradually increase first the blood flow rate to reach the desired target value after 5 minutes. Start the plasma separation in therapy modus first with a plasma flow rate of maximum 20 %, then gradually increase the plasma flow rate to achieve a suitable value after another 5 minutes. Plasma flow rate should at least not exceed 30 % of the effective blood flow rate.
- Monitor the machine during treatment to ensure that the plasma-buffer mixture downstream of the H.E.L.P. precipitate filter is clear.
- Emergency medication for the management of shock should be readily available.
- PTT or ACT should be determined during treatment initially at a plasma treatment volume of 600 ml and at appropriate intervals thereafter to monitor systemic and continuous anticoagulation to avoid clotting and to watch the heparin adsorber function.
- Continuous anticoagulation should be stopped accordingly to the measured PTT or ACT.
- If, during a treatment session, there is any evidence of heparin adsorber malfunction (e.g., adsorber not completely filled with fluid, or air bubbles in adsorber), or if the plasma upstream of the heparin adsorber is turbid, the clotting parameters should be determined immediately. If the PTT and/or ACT are not detectable, the measurement should be repeated until PTT and/or ACT return to normal. In any other cases the replacing of the heparin adsorber or the stop of therapy is recommended.
- During H.E.L.P. treatment the evaluation of the dosage of a heparin bolus must follow the fact that the bolus heparin will be partially adsorbed in heparin adsorber due to the principle of plasma separation.

After Treatment

- Discard any H.E.L.P. solutions remaining after a treatment session.
- All patients should have the blood clotting parameters determined after a treatment session for coagulation monitoring: i.e. activated partial thromboplastin time (PTT), prothrombin time (PT), activated clotting time (ACT), international normalized ratio (INR) and fibrinogen.
- In the rare event of heparin adsorber malfunction, larger quantities of heparin may enter the patient with the potential risk of life-threatening hemorrhage. In this case, the administration of protamine chloride/sulfate should be considered as an emergency measure, complying with the manufacturer's instructions.
- An H.E.L.P. apheresis treatment session takes 2 to 3 hours. The patient is mobile immediately thereafter and can leave the hospital unless the APTT, ACT, PT, INR or fibrinogen results suggest otherwise.
- H.E.L.P. apheresis may eliminate medications to variable degrees, lowering drug levels in patients by up to 60 % during an apheresis session. Medications should be taken **after** a session if at all possible.

Long-term Treatment

- During long-term treatment, Hb, vitamin E and C3/C4 levels should be monitored periodically. Patients with low initial serum iron and/or fibrinogen concentrations are recommended to have these parameters monitored periodically.
- Monitoring of immunoglobulin levels at suitable intervals is recommended.

1.6 Information for the Responsible Organization

1.6.1 Training by Manufacturer prior to Commissioning

The responsible organization may only use the machine after the manufacturer has trained the user based on these instructions for use.

1.6.2 Requirements on the User

The machine may only be used by skilled personnel who are duly trained and instructed for its appropriate operation according to the contents of these instructions for use.

The responsible organization must ensure that the instructions for use are read and understood by all persons entrusted with any kind of work on or with the machine. The instructions for use must permanently be available for the user.

Prior to using the machine, check for safe functioning and correct condition of the machine.

1.6.3 Conformity

The Plasmat® Futura complies with the requirements of the following generally applicable standards in their respective valid version:

- ANSI/AAMI/IEC 60601-1 (ed. 3; ed. 3.1)

Additional equipment connected to the analog or digital interfaces of the machine must demonstrably meet their relevant IEC specifications (e.g. IEC 60950-1/EN 60950-1 for information technology equipment and IEC 60601-1 for electromedical devices). Also, all configurations must comply with the requirements for medical electrical equipment acc. to the standard IEC 60601-1:2012 (clause 16, ME systems). After installation or subsequent modification the overall system must demonstrably not result in any unacceptable risk.

Persons connecting additional devices to signal input or output components configure the system and are therefore responsible for ensuring that all requirements for ME systems (according to IEC 60601-1:2012, clause 16) are demonstrably complied with and that the required accompanying documents for the overall system are made available to the user. Thereby, local regulations take priority over the requirements mentioned above. In case of queries, please contact your local specialist dealer or technical service.

In each country the machine is distributed provided that the machine is registered and classified according to the local regulations.

1.6.4 Manufacturer's Responsibility

The manufacturer, assembler, installer or implementer shall only be responsible for the effects on the safety, reliability and performance of the machine, if

- the assembly, expansion, readjustments, changes or repairs were carried out by an authorized person,
- the electrical installation of the affected premises comply with the valid national requirements on the equipment of medical treatment rooms (i. e. VDE 0100 part 710 and/or IEC60364-7-710).

The device may only be operated, if

- the manufacturer or an authorized person acting on behalf of the manufacturer has carried out a functional check on site (initial commissioning),
- the persons appointed by the responsible organization to use the machine have been trained in the correct handling, use and operation of the medical product with the aid of the instructions for use, enclosed safety and maintenance information.

1.6.5 Modifications of the Machine

WARNING!

Risk to the patient or risk to the user due to modifications of the machine!

- It is not allowed to modify the machine.

1.6.6 Preventive Maintenance and Technical Safety Inspection

NOTICE!

Repairs and maintenance may be performed only by personnel authorized and trained by the manufacturer.

Regular Preventive Maintenance

No special maintenance by the user is required.

The preventive maintenance is recommended to be performed every 12 months, according to the specified check list in the service manual and with reference to the instructions for use, and shall be documented.

Technical Safety Inspection

A technical safety inspection shall be performed and documented every 12 months, according to the specified check list in the service manual and with reference to the instructions for use.

Battery

The lithium battery on PCB User Interface should be replaced after 5 years to maintain the full functionality of the machine. Dispose of the battery according to local waste treatment regulations.

Service Manual and Technical Training

The service manual can only be provided after participation in a technical training.

1.6.7 Expected Service Life

For the Plasmat® Futura machine, B. Braun Avitum AG specifies no service life.

Provided that

- only approved spare parts are used
- maintenance and service are performed by trained technicians in accordance with the service manual
- the technical safety inspection is performed regularly and current results are comparable with initial results

the machine is fully operable.

In addition, the machine performs a series of self tests before each therapy in order to ensure that all safety relevant functionalities are available.

1.6.8 Technical Changes

We reserve the right to change our products in line with further technical developments.

1.7 Disposal

1.7.1 Disposal of Waste Products

After use, the components of the H.E.L.P. Futura treatment set may potentially be contaminated with pathogens of transmissible diseases. The user is responsible for the correct disposal of waste products, e.g. bags, used blood lines or used filters.



Disposal must be carried out according to local regulations and internal procedures of the responsible organization.

1.7.2 Taking Back of Old Machines

Plasmat® Futura machines may be returned to the manufacturer for disposal in accordance with the applicable disposal guidelines (directive 2012/19/EU).



The company B. Braun Avitum AG guarantees the taking back of old Plasmat® Futura machines.

The machine has to be disinfected according to regulations before shipment and disposal.

Table of contents

2	Product Description	23
2.1	Functional Description	23
	2.1.1 Principle	23
	2.1.2 Function	24
2.2	Machine	26
2.3	Control Elements	30
2.4	Monitor Layout and Functions.....	33
2.5	Overview of all Icons.....	38
2.6	Parameter Setting	40
2.7	Symbols on the Machine.....	45

2 Product Description

2.1 Functional Description

2.1.1 Principle

Plasmat® Futura is a plasma therapy unit that, together with the H.E.L.P. apheresis treatment unit, performs H.E.L.P. apheresis therapy (H.E.L.P. stands for Heparin-induced Extracorporeal LDL Precipitation).

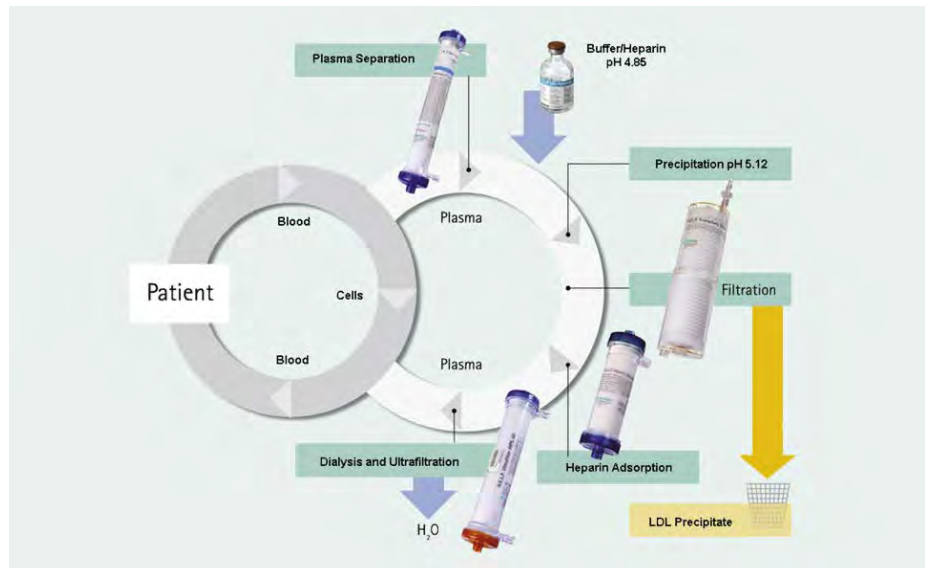

Fig. 2-1 Principle of H.E.L.P. apheresis treatment

The first step of the procedure is plasma separation. The cellular blood components are directly reinfused to the patient along with the treated plasma. The plasma is mixed with a heparinized acetate buffer at a ratio of 1:1. LDL, fibrinogen and Lp(a), together with the heparin, form a precipitate in the acid pH range that is filtered out in the subsequent step. Excessive heparin is removed from the treated plasma using a heparin adsorber. In the last step, the plasma is adjusted to its initial volume and initial physiological pH value using bicarbonate dialysis and then reinfused into the patient along with the cellular blood components.

2.1.2 Function

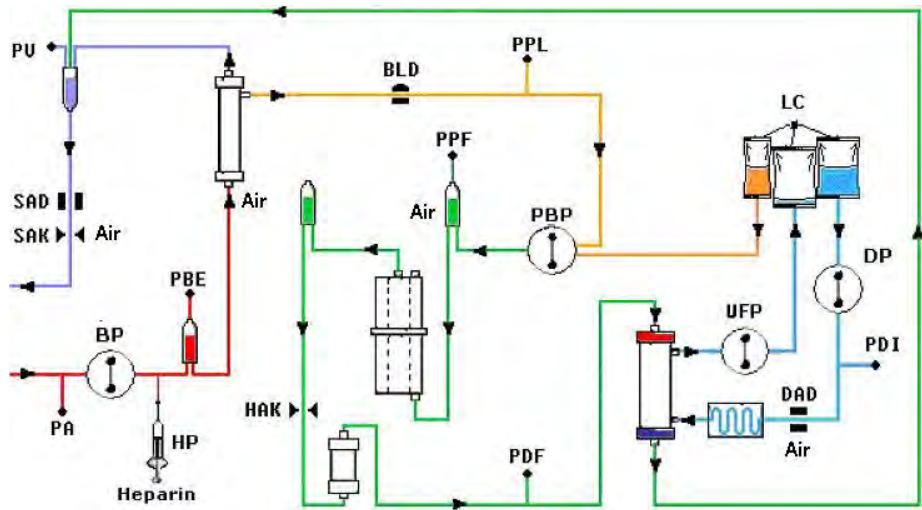

Fig. 2-2 Flow chart of Plasmat® Futura

Sensors		Pumps	
PA	Arterial pressure	BP	Blood pump
PBE	Prefilter pressure ^a	HP	Heparin pump
PV	Venous pressure	PBP	Plasma/buffer pump
PPL	Plasma pressure	UFP	Ultrafiltration pump
PPF	Precipitate filter pressure	DP	Dialysate pump
PDF	Dialyzer pressure		
PDI	Dialysate inlet pressure	Actuators	
BLD	Blood leak detector	SAK	Tubing clamp
SAD	Safety air detector	HAK	Heparin adsorber clamp
DAD	Dialysate air detector		
LC	Load cell		

a. Pressure before plasma filter

The blood pump (BP) delivers the blood from the patient’s venous access to the plasma filter. The blood pressure is monitored via the arterial pressure transducer (PA). The heparin pump (HP) controls the heparin output for anticoagulation in the arterial line. The blood inlet pressure into the plasma filter is monitored via the prefilter pressure (PBE) of the arterial chamber.

Blood that is separated in the plasma filter is returned via the venous line to the venous chamber where it is mixed with the treated plasma which flows back via the reinfusion line. The reinfusion volume is equivalent to the volume of the separated plasma. The venous chamber monitors blood reinfusion via a venous pressure transducer (PV). The venous line is monitored by a safety air detector (SAD) and closed by a tubing clamp (SAK) as soon as air is detected in the system.

The separated plasma is monitored after the plasma filter by a blood leak detector (BLD). Plasma flow is regulated via measurement of plasma pressure (PPL).

Plasma and heparinized acetate buffer are delivered via a plasma/buffer pump (PBP), in which a double pump segment is inserted, to the precipitate chamber. Plasma and heparinized acetate buffer are mixed at a ratio of 1:1. The resulting precipitate is filtered in the subsequent precipitate filter. The precipitate filter pressure transducer (PPF) monitors the inlet pressure of the precipitate filter. The precipitate chamber level valve and sensor control the fluid level in the precipitate chamber.

The filtrate which is free from LDL is routed via the heparin adsorber chamber to the heparin adsorber where the excessive heparin is removed. The heparin adsorber chamber level valve and sensor control the fluid level in the heparin adsorber chamber. The automatic clamp (HAK) in front of the heparin adsorber closes in case of a bypass during therapy.

In the dialyzer, the plasma is dialyzed with a sterile bicarbonate solution at a ratio of at least 1:2. The physiological pH value of the plasma is restored and the induced volume removed by dialysis and ultrafiltration. The dialyzer pressure (PDF) monitors the inlet pressure of the dialyzer. The ultrafiltration rate, bicarbonate dialysate and buffer solution are balanced by the load cell (LC).

Dialysis fluid (inflowing fluid) and dialysate (outflowing fluid) are delivered via the dialysate pump (DP) and the ultrafiltration pump (UFP). The solution is heated in a plate warmer before flowing through the dialyzer. The dialysate air detector (DAD) detects air in the dialysis fluid line. The pressure on the dialysis side is monitored via the inlet pressure of the dialysis fluid (PDI).

2.2 Machine

Front View

2

- 1 IV-pole (height-adjustable)
- 2 LCD graphic monitor
- 3 Upper module
- 4 Heparin syringe pump
- 5 Central module
- 6 Front panel with attachment for H.E.L.P. Futura kit
- 7 Plate warmer
- 8 Bag holder/load cell
- 9 Base column
- 10 Base with brakes

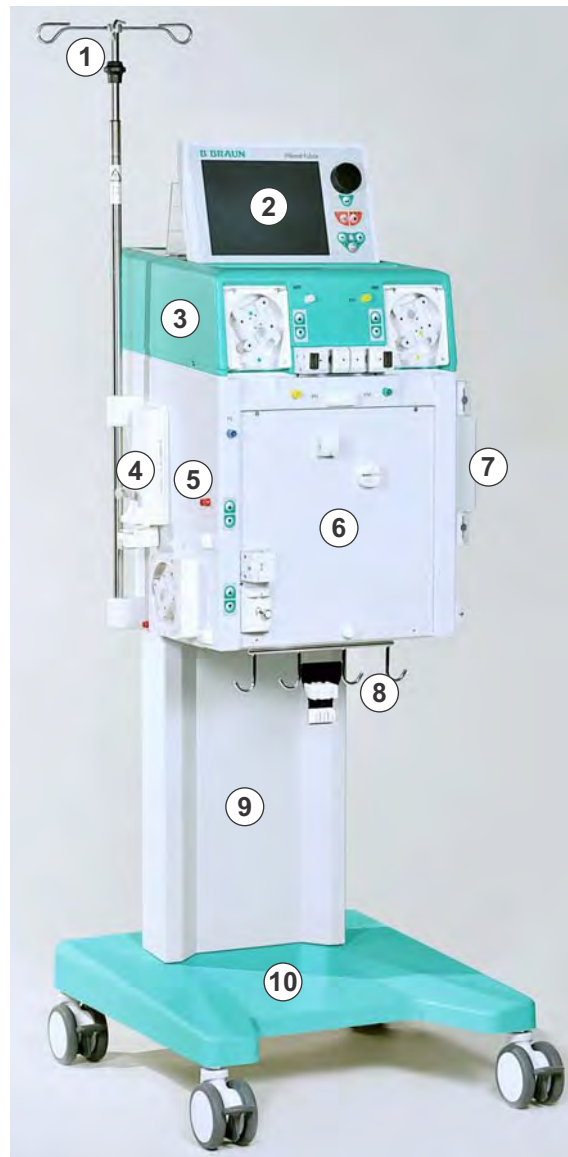

Fig. 2-3 Front view

Upper Module

- 1 LCD graphic color monitor
- 2 Controls on monitor
- 3 Connection to valve for automatic level setting in the heparin adsorber chamber
- 4 Precipitate filter pressure (PPF) transducer
- 5 Ultrafiltration pump (UFP)
- 6 Manual control for level setting in the heparin adsorber chamber
- 7 Manual control for level setting in the precipitate chamber
- 8 Plasma/buffer pump (PBP)
- 9 Holder for heparin adsorber chamber with sensor for level monitoring (HCLD)
- 10 Holder for precipitate chamber with sensor for level monitoring (PCLD)
- 11 Plasma pressure (PPL) transducer
- 12 Dialyzer pressure (PDF) transducer

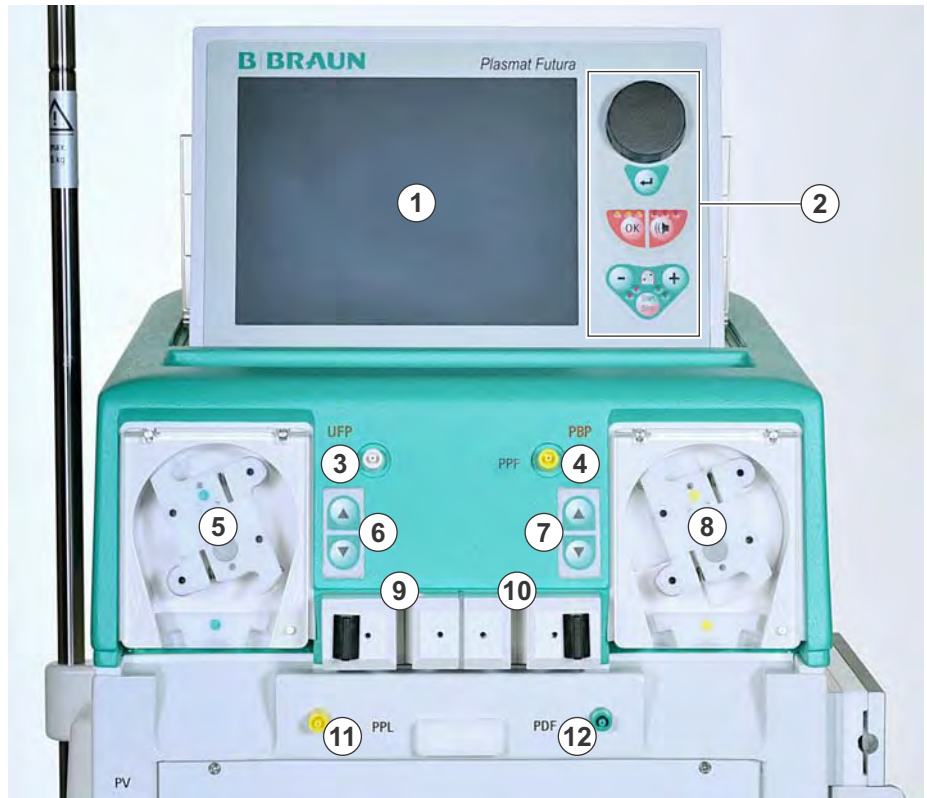

Fig. 2-4 Upper module

Central Module

- 1 Plasma pressure (PPL) transducer
- 2 Upper holder for H.E.L.P. Futura kit
- 3 Dialyzer filter pressure (PDF) transducer
- 4 Venous pressure (PV) transducer
- 5 Blood leak detector (BLD)
- 6 Heparin adsorber clamp (HAK)
- 7 Heparin syringe pump (calibrated for 30 ml Omnifix[®])
- 8 Prefilter pressure (PBE) transducer
- 9 Manual level regulator for venous chamber
- 10 Venous safety air detector (SAD)
- 11 Tubing clamp (SAK)
- 12 Manual level regulator for arterial chamber
- 13 Blood pump
- 14 Arterial pressure (PA) transducer
- 15 Holder for arterial chamber
- 16 Lower holder for H.E.L.P. Futura kit

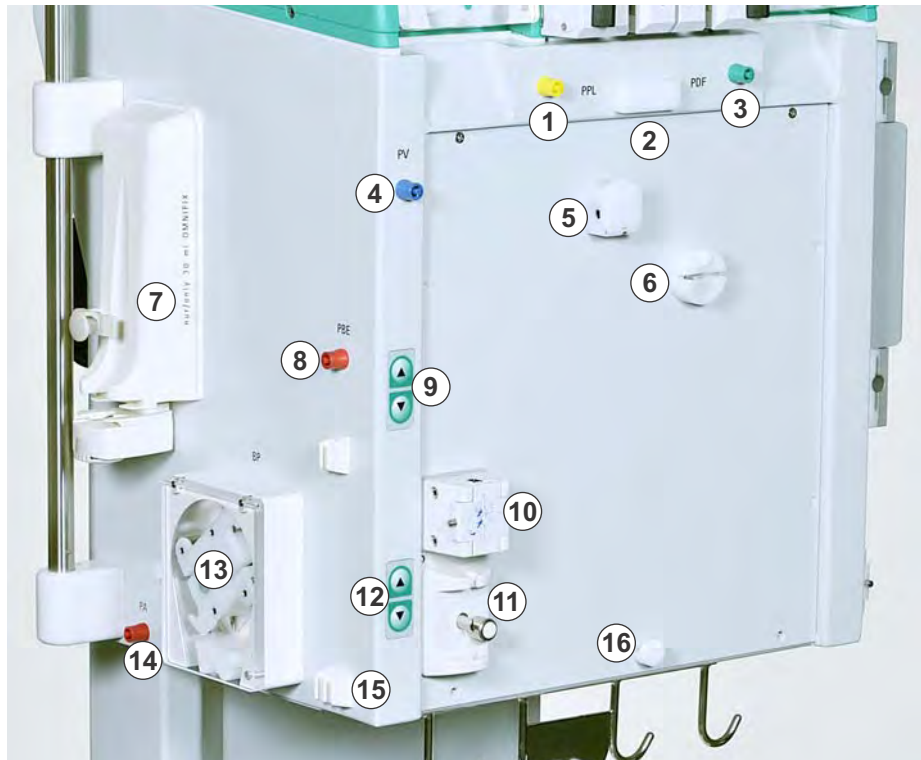

Fig. 2-5 Central module, front-left view

- 1 Plate warmer
- 2 Dialysate pump (DP)
- 3 Dialysate inlet pressure (PDI) transducer
- 4 Dialysate air detector (DAD)



Fig. 2-6 Central module, front-right view

Rear View

- 1 Monitor support
- 2 IV-pole
- 3 On/Off switch
- 4 Mains connection
- 5 Hand crank for pumps
- 6 Handles
- 7 Connection for potential equalization
- 8 Connection for Trend Viewer (option)

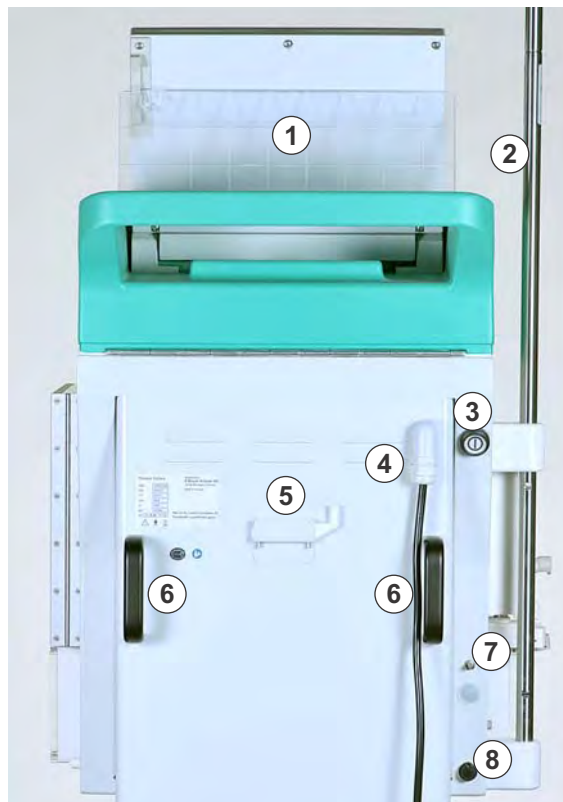

Fig. 2-7 Rear view

2.3 Control Elements

On/Off Switch



The On/Off switch is located at the top right of the machine's rear side (see Fig. 2-7 Rear view (29)). It acts as a power switch that connects and disconnects the machine from the mains supply.

This switch has two stable positions:

- pushed down: machine is switched on
- released: machine is switched off

The machine remains in the current state (On or Off) until the switch is pressed again.

WARNING!

Risk of electric shock and fire!

- Complete disconnection from the mains supply results only if the mains plug is removed completely from the mains socket. If the power switch is switched off the machine is not completely disconnected!

Level Adjustment Keys



The level adjustment keys are located at the front of the upper module (see Fig. 2-4 Upper module (27)) and at the front of the central module (see Fig. 2-5 Central module, front-left view (28)).

These keys adjust the fluid level in the

- heparin adsorber chamber (HCLD)
- precipitate chamber (PCLD)
- venous chamber
- arterial chamber

The level adjustment in the respective chamber is performed with the directly adjacent level adjustment keys. The ▲ key raises the level in the chamber, the ▼ key lowers the level.

- 1 Rotary knob
- 2 *Enter* key
- 3 *OK* key with LEDs
- 4 *Alarm* key with LEDs
- 5 Blood pump operating keys

Controls on the Monitor

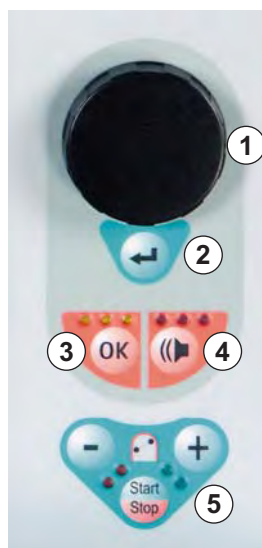

Fig. 2-8 Control elements on monitor

The **rotary knob** (Fig. 2-8, ①) moves the cursor on the screen.

Display in lines:

- clockwise rotation: cursor moves from left to right
- counterclockwise rotation: cursor moves from right to left

Display in columns:

- clockwise rotation: cursor moves from top to bottom
- counterclockwise rotation: cursor moves from bottom to top

The **Enter key** (②) must be pressed to activate selected commands and to confirm entered parameter settings.

The **OK key** (③) must be pressed to confirm important actions, such as:

- phase change (e.g. change from priming/rinsing phase to therapy phase)
- terminating parameter setting
- acknowledging messages that require immediate action (e.g. prompt for turning over dialyzer during priming and rinsing phase)

When the *OK* key is active, the **yellow LEDs** above it light. These LEDs blink during adjustment of parameters with relevance to patient safety.

When an acoustic alarm occurs, the alarm tone is switched off with the **Alarm key** (④). After eliminating the cause of the alarm, the alarm is acknowledged by pressing the *Alarm* key again in order to continue with the respective phase.

When the *Alarm* key is active, the **red LEDs** above it light.



Alarms initiated by opening a pump cover are reset by closing the pump cover.

- 1 – key
- 2 + key
- 3 Red LEDs
- 4 Green LEDs
- 5 *Start/Stop* key

Blood Pump Operating Keys (⑤)

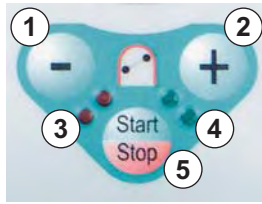

Fig. 2-9 Blood pump operating keys

The **- key** (Fig. 2-9, ①) and the **+ key** (②) lower or raise the delivery rate of the blood pump.

If the blood pump stops during an alarm, the **red LEDs** (③) light. If the blood pump runs, the **green LEDs** (④) light. If both LED indicators blink alternately, the blood pump has stopped and must be started manually with the **Start/Stop key** (⑤). The running blood pump can also be stopped with this key.

2.4 Monitor Layout and Functions

Monitor Layout

- 1 Status bar
- 2 Alarm/Note line
- 3 Display area
- 4 Menu bar

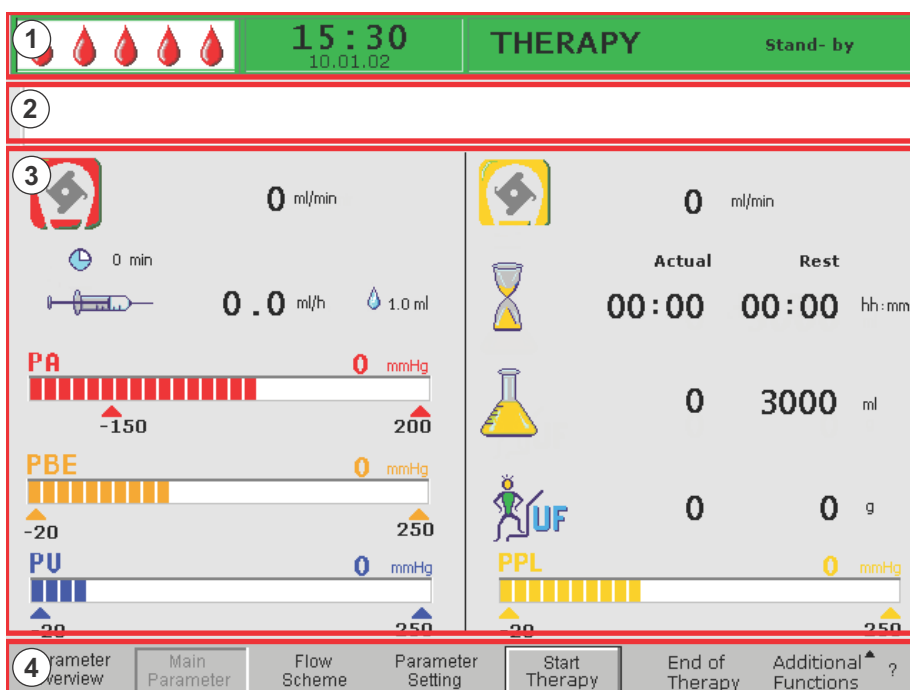

Fig. 2-10 Monitor layout

The **status bar** (Fig. 2-10, ①) indicates:

- status of blood pump
 - stopped: one stable and four blinking drops
 - running: increasing and decreasing number of drops
- current time and date
- treatment phase (priming, therapy, reinfusion)
- current status or step of phase (stand by, running)

The **Alarm/Note line** (②) displays alarm texts and warning messages.

The **display area** (③) displays all parameters which are relevant in the current phase.

The **menu bar** (④) displays the different menu items that can be selected depending on the treatment phase. Functions are selected with the rotary knob and activated with the *Enter* key.

Screens

Three display variants (“screens”) can be selected for the display area:

- Main parameter screen (Fig. 2-11)
- Parameter overview screen (Fig. 2-12)
- Flow scheme screen (Fig. 2-13)

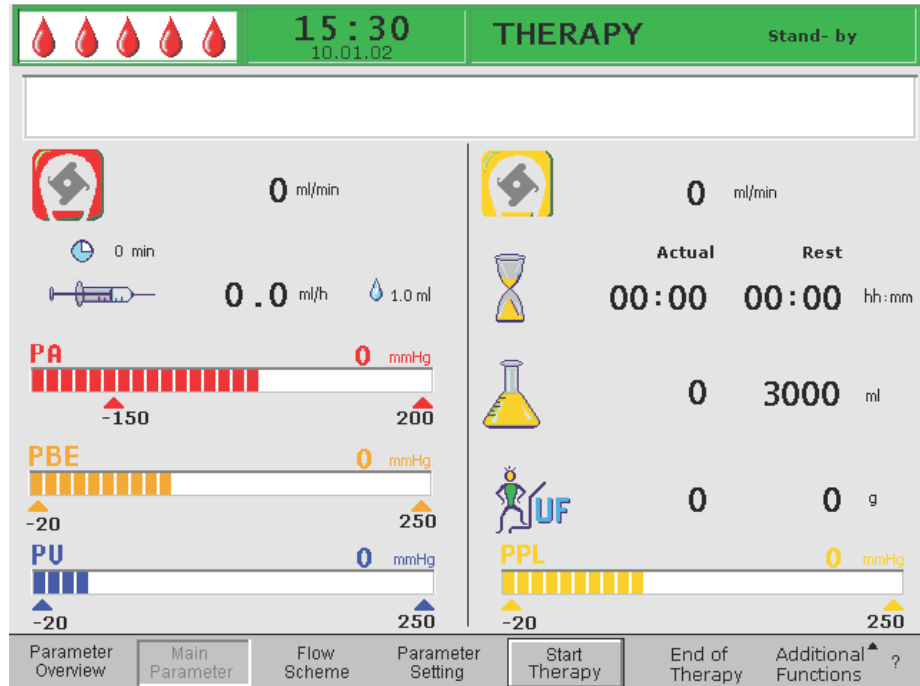

Fig. 2-11 Main parameter screen



Fig. 2-12 Parameter overview screen

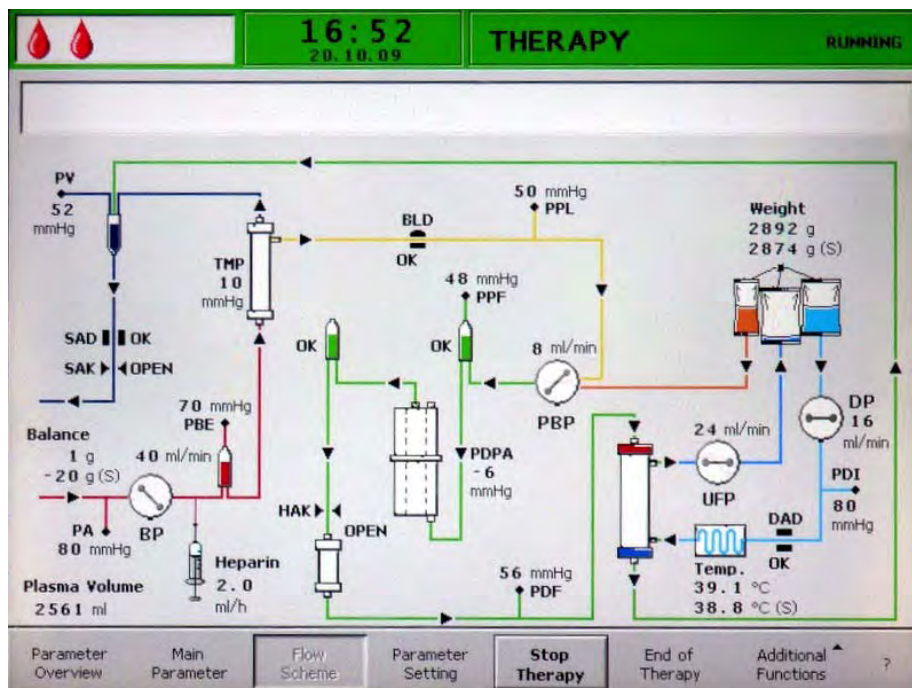

Fig. 2-13 Flow scheme screen

The *Main Parameter* screen (Fig. 2-11) is displayed by default.

In addition, a *Help* screen (Fig. 2-14) is available. This screen can be selected from any screen with the ? button in the menu bar.

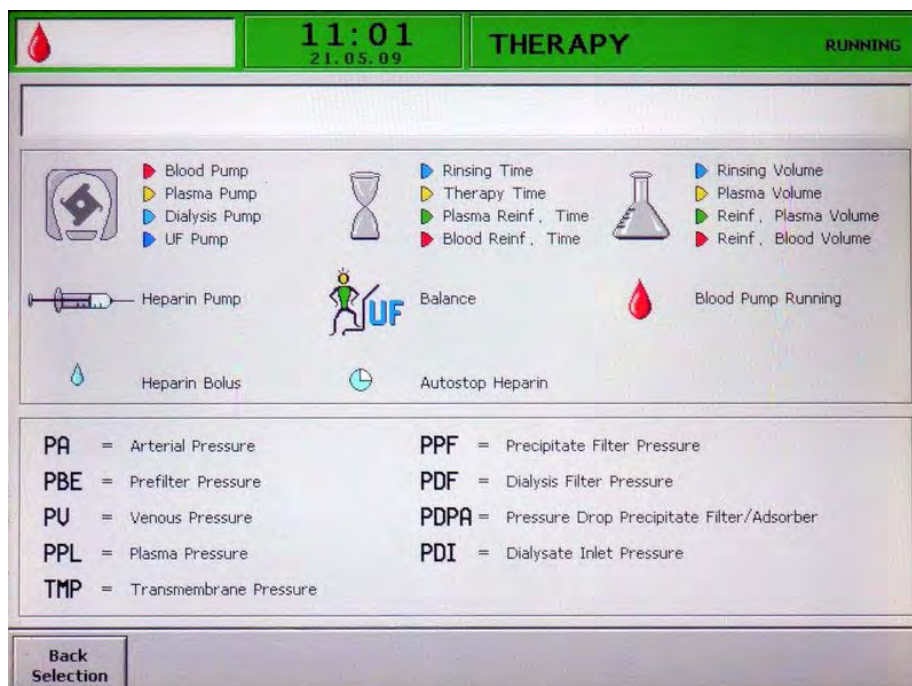

Fig. 2-14 Help screen

The symbols and abbreviations used for the different pressures in the display areas are explained on the *Help* screen. To return to the previous screen, select *Back Selection* or wait for the screen to return automatically after 30 seconds.

Menu Bar

The items indicated in the menu bar depend on the currently selected mode:

Help Bar

Back Selection	
----------------	--

Test Bar

RETEST		END	?
--------	--	-----	---

Settings Bar

SETTING		Back Selection	?
---------	--	----------------	---

Priming Bar

Parameter Overview	Main Parameter	Flow Scheme	Parameter Setting	Start [Stop] Priming	Therapy	Additional Functions [▲]	?
--------------------	----------------	-------------	-------------------	----------------------	---------	-----------------------------------	---

New Therapy

Stop Bolus
Heparin Bolus
Balance Reset

Therapy Bar

Parameter Overview	Main Parameter	Flow Scheme	Parameter Setting	Start [Stop] Therapy	End of Therapy	Additional Functions [▲]	?
--------------------	----------------	-------------	-------------------	----------------------	----------------	-----------------------------------	---

Back to Therapy

Blood Reinfusion

Plasma Reinfusion

Reinfusion Bar

Parameter Overview	Main Parameter	Flow Scheme	Parameter Setting	Start [Stop] Plasma	Reinfusion Type [▲]	Additional Functions [▲]	?
--------------------	----------------	-------------	-------------------	---------------------	------------------------------	-----------------------------------	---

New Therapy

Fig. 2-15 Items in the menu bar

Use the rotary knob to scroll through the menu items. A currently selected (i.e. active) menu item is shown recessed (like pressed) with gray-colored labeling (Fig. 2-16, ①). The menu item selected with the current cursor position is shown embossed (like not pressed, ②). Menu items which cannot be selected in the current mode are shown with gray-colored letters (③).

Parameter Overview ①	Main Parameter	Flow Scheme	Parameter Setting ②	Start Priming	Therapy ③	Additional Functions [▲]	?
----------------------	----------------	-------------	---------------------	---------------	-----------	-----------------------------------	---

Fig. 2-16 Functioning of the menu bar

Alarms and Warnings

Alarms and warnings are always accompanied by acoustic warning tones.

When an alarm occurs, the screen display automatically changes to the Flow Scheme. A corresponding message is displayed in the Alarm/Note line (Fig. 2-10, ②).

Warnings serve to point out a situation and are also displayed in the Alarm/Note line. If a warning requires an action, a corresponding *Warning* window appears (Fig. 2-17). These warnings and messages must be acknowledged by pressing the *OK* key to continue in the respective phase.

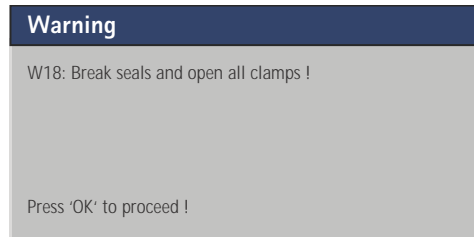

Fig. 2-17 Example for *Warning* window

For more information about alarms and warnings see chapter 9 Troubleshooting (119).











2.5 Overview of all Icons

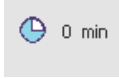





The parameter icons (symbols) indicated in the *Main Parameter* screen depend on the current treatment phase. Open the *Help* screen (see section 2.4 Monitor Layout and Functions (33)) to get further information about the meaning of symbols and the abbreviations used.

The icons are color-coded, e.g. for the pumps (flows) or volumes:

- blue: rinsing
- red: blood side
- yellow: plasma side
- green: reinfusion side

Red is also used for arterial pressure and dark blue for venous pressure (see table below).

Icon	Description
	Heparin flow in ml/h
	Heparin bolus in ml
	Autostop heparin in min
	Rinsing time [Actual/Rest] in min
	Rinsing volume [Actual/Rest] in ml
	Blood flow in ml/min
	Blood reinfusion time in min
	Blood reinfusion volume in ml
	Plasma flow in ml/min This parameter value is set in % of blood flow and indicated in ml/min!
	Plasma volume [Actual/Rest] in ml

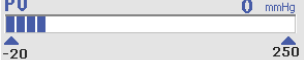
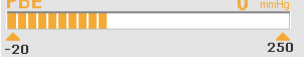
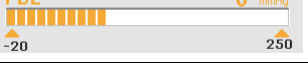
Icon	Description
	Therapy time [Actual/Rest] in hh:mm
	Reinfusion flow in ml/min
	Reinfusion time in min
	Reinfusion volume in ml
	<p>Balance in g</p> <p>This parameter provides the possibility of additionally removing the existing physiological saline solution or to balance the physiological saline solution required for blood reinfusion. When setting a balance, it must be observed that this changes the hematocrit value of the blood and could make the separation of plasma sometimes more difficult!</p>
	Arterial pressure in mmHg
	Venous pressure in mmHg
	Prefilter pressure in mmHg
	Plasma pressure in mmHg

2.6 Parameter Setting

Parameters can be set in all three screens (*Main Parameter*, *Parameter Overview* and *Flow Scheme*) by selecting *Parameter Setting* in the menu bar and pressing the *Enter* key.

Parameter Setting in the Main Parameter Screen

1. Use rotary knob to select *Parameter Setting* item (Fig. 2-18, ①) in menu bar and press *Enter* key.
 - ↪ All parameters which can be changed are displayed in red (Fig. 2-18).
 - ↪ In the Alarm/Note line, the message *W16: Press 'OK' to return to menu selection!* (②) appears to indicate that the *OK* key must be pressed to quit the parameter setting.

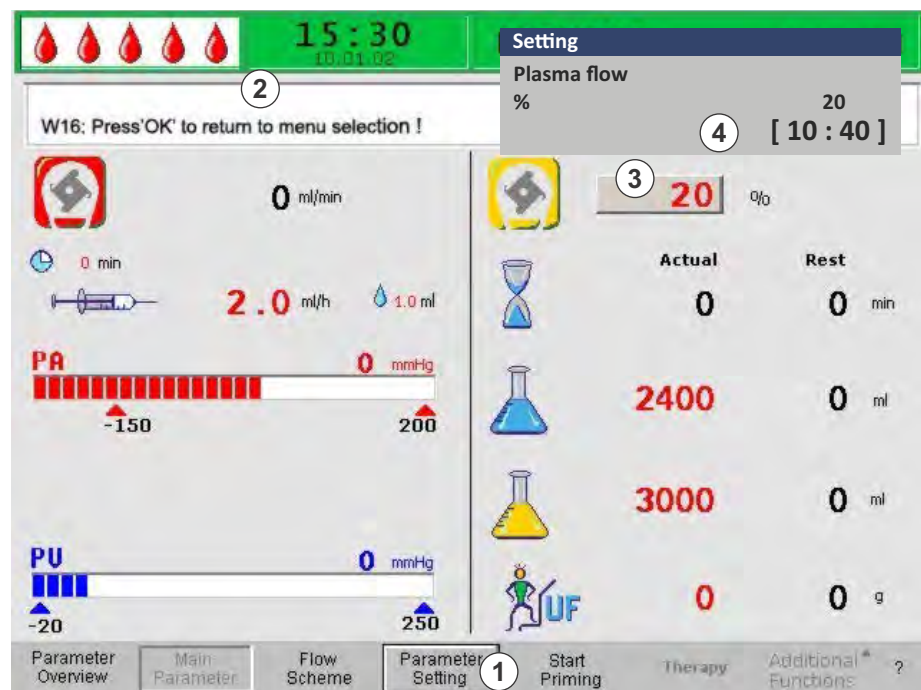

Fig. 2-18 Parameter selection in the *Main Parameter* screen

2. Use rotary knob to scroll through parameters which can be changed.
 - ↪ The currently selected parameter value field is shown embossed (like not pressed) with a gray background (Fig. 2-18, ③). The range for parameter setting is displayed in the *Setting* window that appears (④). If a parameter is relevant for patient safety, the currently set value is indicated above the setting range.

3. Press *Enter* key to activate setting dialog for selected parameter.
 - ↪ The parameter value field is shown with a red background and white labeling (Fig. 2-19, ①).

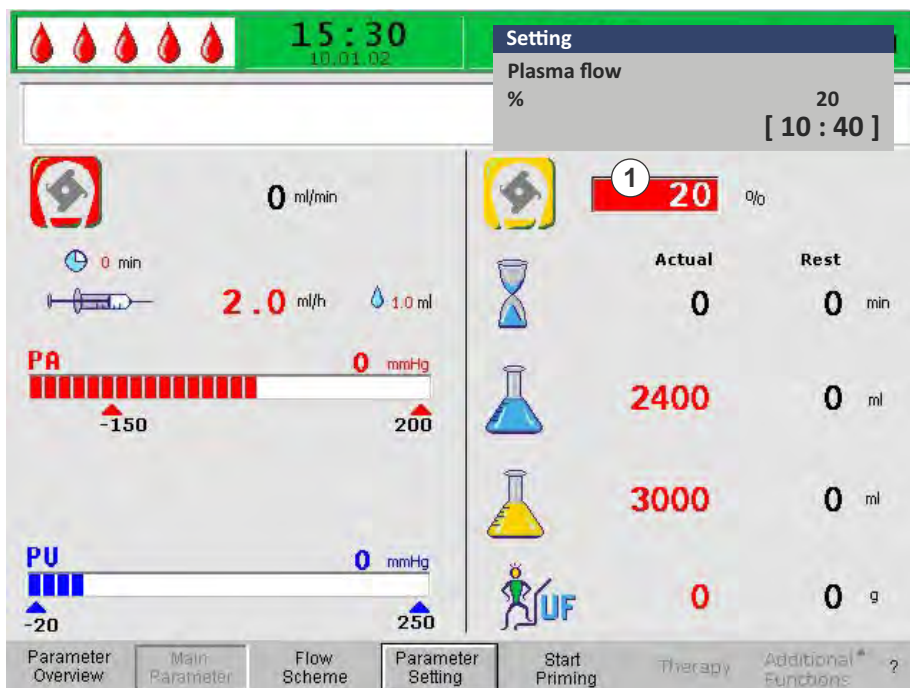

Fig. 2-19 Parameter setting in the *Main Parameter* screen

4. Use rotary knob to scroll through possible parameter settings until desired value is reached and press *Enter* key to confirm.



If a parameter is safety relevant, changing this parameter must be confirmed with the *OK* key. A corresponding message appears in the Alarm/Note line and the LEDs above the *OK* key blink.

5. In case of a safety relevant parameter, press *OK* key to confirm setting.
6. If necessary, change all other parameters accordingly.
7. Press *OK* key to quit parameter setting.
 - ↪ The cursor moves back to the menu bar in the *Main Parameter* screen.

If no setting is performed within a time period of 15 seconds, the previously selected screen reappears automatically.

Parameter Setting in the Parameter Overview Screen

1. Use rotary knob to select *Parameter Overview* item (Fig. 2-20, ①) in menu bar and press *Enter* key.
 - ↪ The *Parameter Overview* screen appears. For a better overview, Blood Flow (red), Plasma Flow (yellow) and Return Flow (green; in reinfusion phase only) are marked with colored arrows in this screen (②).



Fig. 2-20 Parameter Overview screen



2. Use rotary knob to select *Parameter Setting* item (Fig. 2-20, ③) in menu bar and press *Enter* key.

- ↳ All parameters which can be changed are displayed in red (Fig. 2-21).
- ↳ In the Alarm/Note line, the message *W16: Press 'OK' to return to menu selection!* (①) appears to indicate that the *OK* key must be pressed to quit the parameter setting.



Fig. 2-21 Parameter selection in the *Parameter Overview* screen

3. Use rotary knob to scroll through parameters which can be changed.
 - ↪ The currently selected parameter value field is shown embossed (like not pressed) with a gray background (Fig. 2-21, ②). The range for parameter setting is displayed in the *Setting* window that appears (③). If a parameter is relevant for patient safety, the currently set value is indicated above the setting range.
4. Press *Enter* key to activate setting dialog for selected parameter.
 - ↪ The parameter value field is shown with a red background and white labeling (Fig. 2-22, ①).



Fig. 2-22 Parameter Setting in the *Parameter Overview* screen



5. Use rotary knob to scroll through possible parameter settings until desired value is reached and press *Enter* key to confirm.



If a parameter is safety relevant, the changing of this parameter must be confirmed with the *OK* key. A corresponding message appears in the Alarm/Note line and the LEDs above the *OK* key blink.



6. In case of a safety relevant parameter, press *OK* key to confirm setting.



7. If necessary, change all other parameter settings accordingly.

8. Press *OK* key to quit parameter setting.

↪ The cursor moves back to the menu bar in the *Parameter Overview* screen.

If no setting is performed within a time period of 15 seconds, the previously selected screen reappears automatically.

Parameter Setting in the Flow Scheme Screen

1. Use rotary knob to select *Flow Scheme* item (Fig. 2-23, ①) in menu bar and press *Enter* key.
 ↳ The *Flow Scheme* screen (Fig. 2-24) appears.

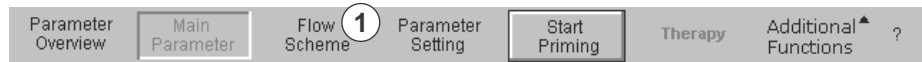

Fig. 2-23 *Flow Scheme* item in the menu bar

2. Use rotary knob to select *Parameter Setting* item (Fig. 2-24, ①) in menu bar and press *Enter* key.
 ↳ The screen changes to the setting screen of the *Parameter Overview*. Here, all settings can be performed as described for this screen (see above).

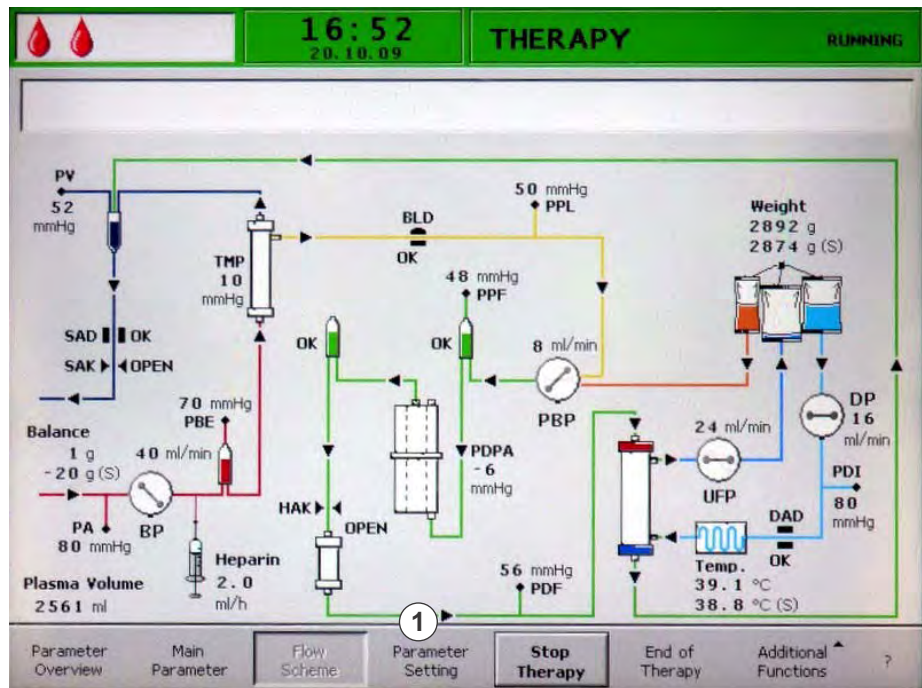

Fig. 2-24 *Parameter Setting* item in the *Flow Scheme* screen

2.7 Symbols on the Machine













	Follow instructions for use Observe safety information
	Risk of injuries or machine damage Follow instructions for use Observe safety information
	Risk of breakage Do not move or lift the machine on the green bar at the rear side
	Risk of machine damage Label indicating the maximum permissible load of the load cell
max  89 kg	Imprint indicating maximum machine weight (inclusive maximum working load)
	Application device type B Classification acc. to IEC 60601-1. Type B is used for devices that are generally not conductive and can be released immediately from the patient.
	This product must not be disposed of as domestic waste. The bar below the symbol indicates that the product has been placed on the market after August 13 th , 2005.
	Potential equalization connection
	Machine ON/OFF Symbol on mains switch indicating a push button with bistable positions. Each position (On and Off) is a stable position.
	Alternating current
	Schematic illustration on safety air detector (SAD) showing the correct way of installing the tube
	Connection for optional Trend Viewer (for service only)

Table of contents

3	Installation and Commissioning	49
3.1	Scope of Supply.....	49
3.2	Storage	49
3.2.1	Storage in Originally Packed Condition	49
3.2.2	Interim Storage of Machines Ready for Operation	49
3.2.3	Decommissioning	50
3.3	Transportation.....	50
3.3.1	Moving the Machine	51
3.3.2	Carrying the Machine	52
3.3.3	Connecting the Machine after Transportation	53
3.4	Installation Site.....	53
3.4.1	Ambient Conditions	53
3.4.2	Electrical Connection	53
3.4.3	Potentially Explosive Areas	54
3.5	Initial Commissioning	54
3.6	Switching On and Off	55
3.7	Settings	55

3 Installation and Commissioning

3.1 Scope of Supply

- Plasmat® Futura apheresis machine
- Instructions for use
- Potential equalization cable (option)
- Trend Viewer (option for technicians)

Goods-in Check

1. When delivered, the machine must be unpacked by authorized personnel, for example a service technician.
2. The machine must visually be checked for completeness and damage by authorized personnel.

3.2 Storage

3.2.1 Storage in Originally Packed Condition

1. Store machine in ambient conditions as specified in section 11.2 Ambient Conditions (174).

3.2.2 Interim Storage of Machines Ready for Operation

1. Disinfect machine.
2. Close SAD cover for storage in order to prevent malfunction of the SAD.
3. Store machine in ambient conditions as specified in section 11.2 Ambient Conditions (174).
4. Disinfect machine before treatment if it was not used for more than 1 week.
5. Check machine visually for any damage if it was not used for more than 1 week.

WARNING!

Risk of electric shock!

- Check housing visually for any damages.
- Check cables for any damages.
- Do not switch on the machine if there is any obvious damage.

WARNING!

Risk to patient due to contamination with pyrogens and endotoxins!

- Before reuse after extended idle times, clean and disinfect the machine according to manufacturer's instructions and local regulations (e.g. hygienic plan).

3.2.3 Decommissioning

1. Disinfect machine.
For appropriate cleaning before moving machine, refer to chapter 8 Disinfection (115).
2. Instruct technical service to empty machine.
3. Store machine in ambient conditions as specified in section 11.2 Ambient Conditions (174).

CAUTION!

Risk of electric shock and machine damage if fluid enters the machine!

- Ensure that no fluid enters the machine.
- Do not wipe the surface too moistly.
- Only use appropriate cleaning agents.

3.3 Transportation

WARNING!

Risk of electric shock if machine is not disconnected from power supply!

- Ensure that machine is disconnected from power supply before transport.

CAUTION!

Cutting and crushing hazard!

- Move or carry machine observing the transport instructions to prevent cutting or crushing hazard.

NOTICE!

To prevent possible filter ruptures and line damages, avoid to transport the machine when fully prepared for treatment!

Storing Cables and Lines

1. Before moving or carrying machine, disconnect and roll up mains cable and possibly connected signal lines (e.g. Trend Viewer).
2. Ensure that no fluid lines are installed or connected.

CAUTION!

Risk of toppling if cables or lines are not safely stored when moving or carrying the machine!

- Ensure that cables and lines are safely stored during transport.
- Move machine slowly.

3. Store cables and lines safely in order to avoid toppling.

3.3.1 Moving the Machine

NOTICE!

Risk of tipping if the machine is tilted by more than 10°!
 Have two or more persons at hand for transporting the machine on stairs and inclined areas. Do not tilt the machine by more than 10°.

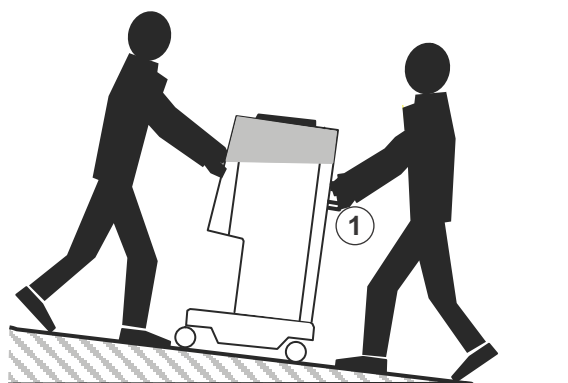

Fig. 3-1 Moving the machine on stairs and slopes (2 persons)

1. Release brakes of all casters (Fig. 3-2, ①) before moving machine. Lift lever (② , arrow) to release a brake.

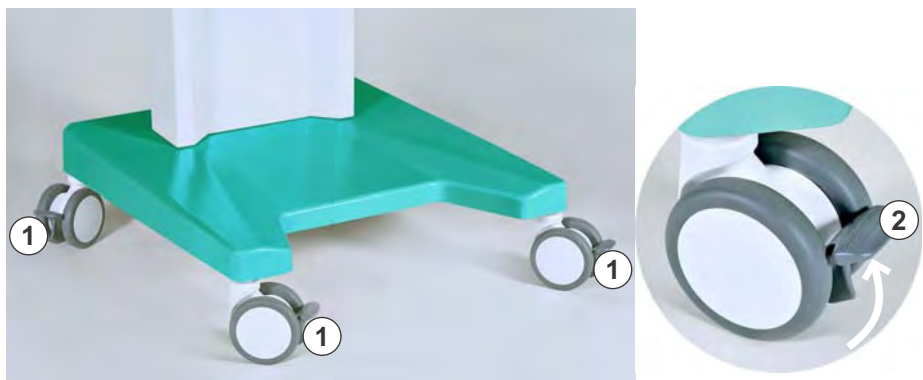

Fig. 3-2 Brakes on casters

2. Move machine while holding it on the handles at rear side (Fig. 3-1, ①).

NOTICE!

Risk of damage due to incorrect transportation (wrong holding points)!
 Do not hold the machine on monitor, on the green upper housing (especially on bar on rear side) or on infusion pole when transporting.

3. After moving, push down levers at all casters to reapply brakes.

3.3.2 Carrying the Machine

⚠ CAUTION!

Cutting and crushing hazard!

- The machine weighs 55 kg. Have two or more persons at hand for carrying. Only use the designated holding points.

For carrying, the Plasmat® Futura can be held at the base, at the handles at the rear panel and at the protrusion at the front of the machine, as shown in Fig. 3-3.

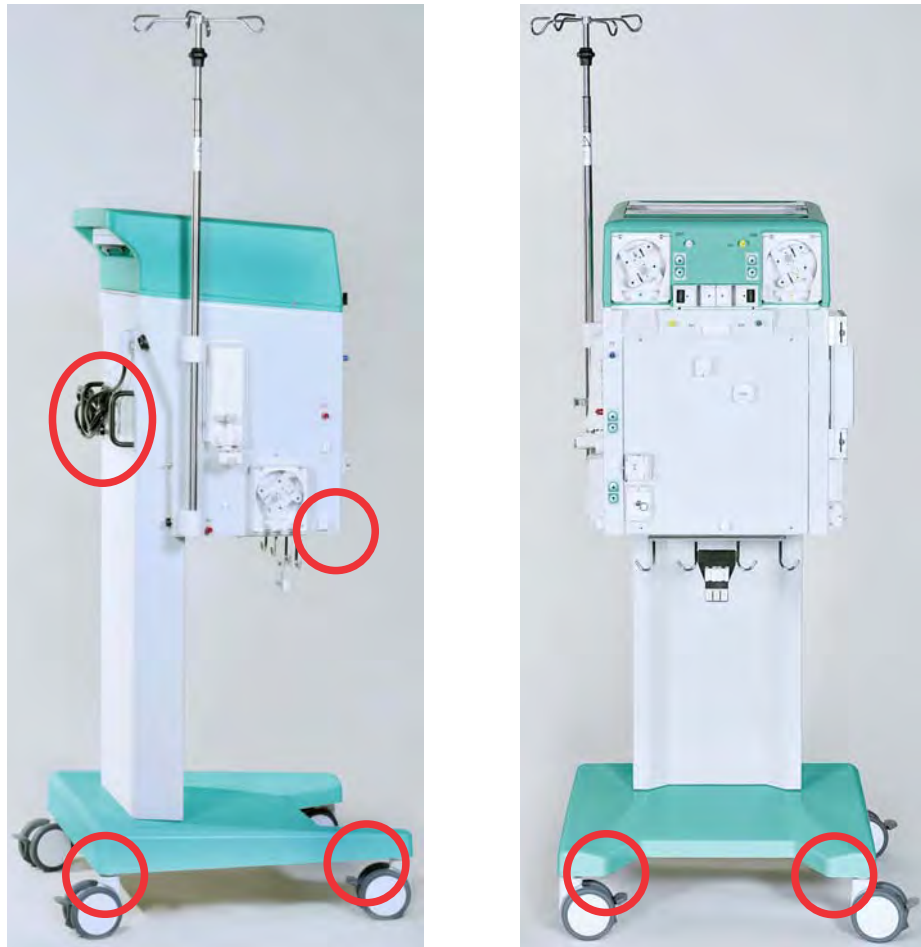

Fig. 3-3 Holding points for carrying the machine

NOTICE!

Risk of damage due to incorrect transportation (wrong holding points)!
Do not hold the machine on monitor, on the green upper housing (especially on the bar on rear side) or on infusion pole when transporting.

3.3.3 Connecting the Machine after Transportation

1. After transportation, apply brakes to all casters.



The mains wall socket must remain accessible to ensure that the mains plug can easily be removed in order to completely isolate the machine from mains supply.

2. Reconnect all cables, signal and blood lines removed for transport.
3. Clean and disinfect machine before usage.

WARNING!

Risk of electric shock or leakage currents due to condensation in the machine!

- Do not switch on the machine immediately after moving through variable temperature.
-

3.4 Installation Site

3.4.1 Ambient Conditions

The ambient conditions of the premises must be in accordance to the local requirements (see technical data).

3.4.2 Electrical Connection

The existing mains voltage must correspond with the voltage specified on the rating plate. The use of extension cables or adapters with the mains cord or the mains socket is NOT permitted. Modifications of the mains cord are forbidden! If the mains cord has to be changed, only the original mains cord listed in the spare parts list must be used.

Electrical installations in the room where the machine will be operated must conform with relevant regulations, e.g. VDE 0100 Part 710 and/or IEC-stipulations (like DIN EN 60309-1/-2 and VDE 0620-1 for example).

Using machines of protection class I the quality of the protective conductor is important. It is recommended to use a mains socket with additional PE-contact pin according to CEE 7/7 for cables with safety plug (Schuko).

WARNING!

Risk of electric shock if machine is not properly grounded!

- The machine must be connected to a mains supply with protective earth.
-

In addition, it is recommended to connect a potential equalization to the machine. When using the machine in combination with other therapeutic devices of protection class I, the electrical potential equalization is also to be connected to every other device as the leakage currents from all connected devices are additive and an electrostatic discharge from the environment to the machine may occur.

⚠ CAUTION!

Risk of electrostatic discharge from other devices!

- Mobile phones and other devices emitting strong electromagnetic radiation should only be used at a minimum distance, according to IEC 60601-1-2 (see technical data).

Regulations and deviations specific to the individual country must also be observed. For further information, call technical service.

3.4.3 Potentially Explosive Areas

The machine may not be operated in areas at risk of explosion.

3.5 Initial Commissioning

Installation and initial commissioning of the machine shall be performed only by technicians authorized by the manufacturer.

Before initial commissioning of the machine, check whether it is complete and undamaged. Ensure that the supply voltage corresponds to the nominal voltage indicated on the type plate of the machine!

NOTICE!

In case of any damage that may call into question the safe use of the machine, the machine may not be switched on. Inform the customer service in charge.

At initial commissioning, the following presettings are performed in the *Settings* menu:

- Contrast LC display
- Cursor speed
- Language
- Plasma/blood ratio
- PPL threshold
- Dialysate/plasma ratio
- Plasma reinfusion flow
- Date and time

3.6 Switching On and Off

NOTICE!

In case of any damage that may affect the safe use of the machine, the machine may not be switched on. Inform the customer service in charge. Only switch on the machine after it has reached room temperature. Make sure that the brakes are applied to all casters. Observe requirements on installation site.

Switching On

1. Press power switch (On/Off switch) on rear side of machine.
 - ↗ The machine switches from Off to On status. After switching on, an automatic self test is initiated (see section 4.1 Switching On and Initial Tests (64)). After successful self test, the *End* menu item is automatically activated in the menu bar.
2. Press *Enter* key to change to start screen.

Switching On after Accidentally Pressing the Power Switch

In case of accidentally switching off the machine by pressing the power switch during a therapy, proceed as follows:

1. Press power switch again.
 - ↗ The warning *W39: Power fail eliminated. Check lines, filters and parameter setting, then restart!* is displayed on the screen.
2. Check lines, filters and parameter settings and press *OK* key.
 - ↗ In case of interruptions less than 15 minutes, the therapy continues.
 - ↗ In case of interruptions longer than 15 minutes, the previous machine status is lost and the start screen appears.

Switching On after a Power Failure

In case of a power failure, a characteristic alarm tone appears. If power supply is restored, the warning *W39: Power fail eliminated. Check lines, filters and parameter setting, then restart!* is displayed on the screen. Proceed as described above.

Switching Off

1. Press power switch (On/Off switch) on rear side of machine.
 - ↗ The machine switches from On to Off status.

3.7 Settings

Basic and default settings may be changed in the *Settings* screen which can be selected from any screen after the self test.

1. Simultaneously press *OK* key and *Alarm* key.
 - ↗ The *Settings* screen (Fig. 3-4) appears, indicating machine data on left side (①) and default parameter settings on right side (②).
 - ↗ If no settings are changed for more than 15 seconds, the screen automatically reverts back to the previously selected screen.

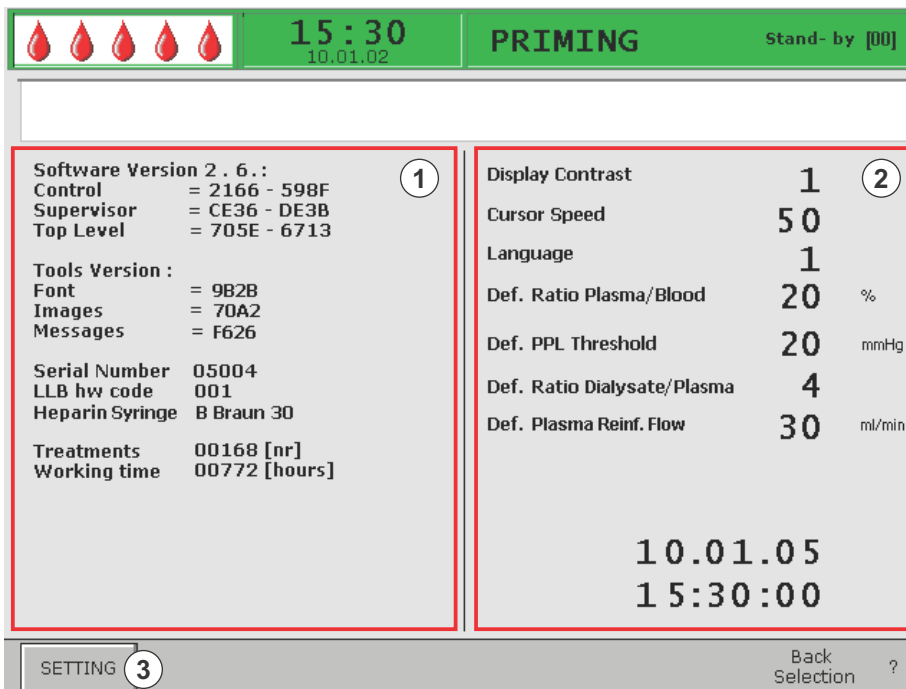

Fig. 3-4 Settings screen



2. To change parameter settings, select *SETTING* menu item (③) and press *Enter* key.
 - ↳ All parameters that can be changed are displayed in red.
3. Use rotary knob to scroll through individual parameters.
 - ↳ The setting field of the currently selected parameter is shown embossed (like not pressed) with a gray background. The *Setting* window displays the allowable setting range.

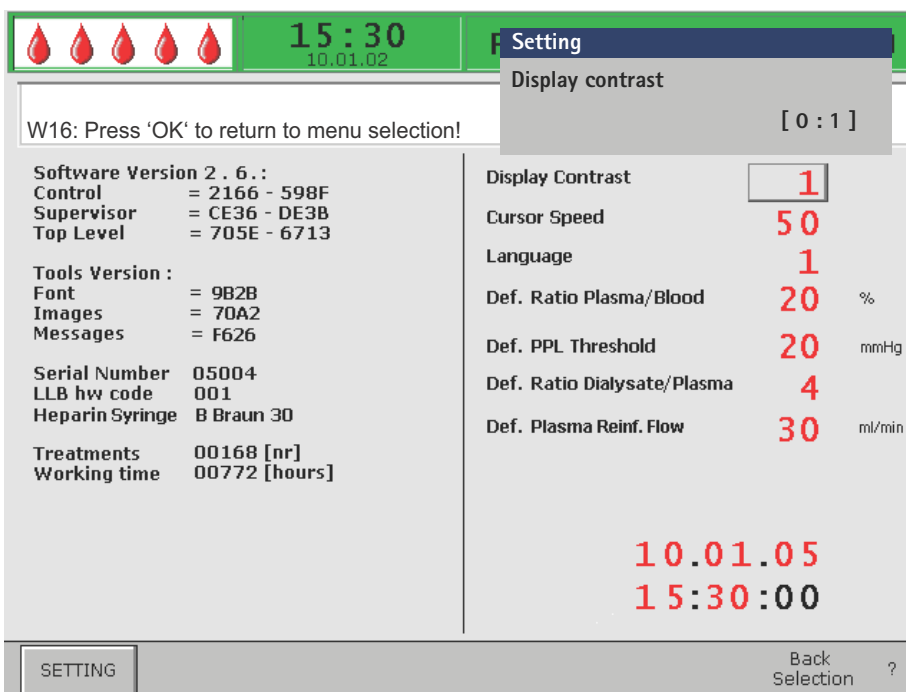

Fig. 3-5 Settings screen - selecting a parameter

4. Press *Enter* key to activate setting for currently selected parameter.
 - ↳ The setting field of the parameter is shown with a red background and white labeling.

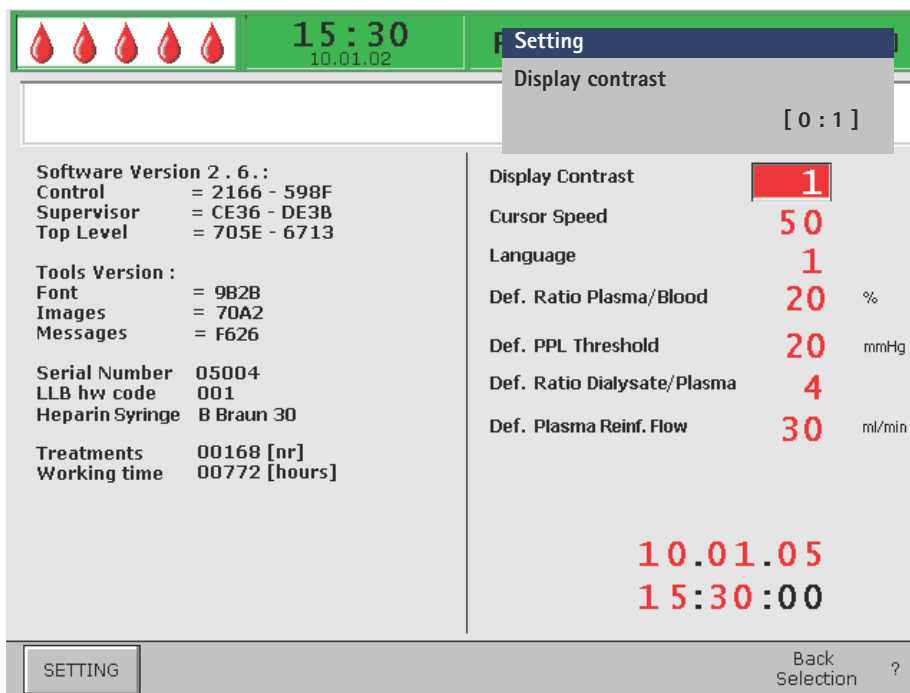

Fig. 3-6 Settings screen - setting a parameter

5. Use rotary knob to scroll through preset parameter values and press *Enter* key to confirm intended setting.
6. Press *OK* key to quit parameter setting.
 - ↳ The cursor changes back to the menu bar of the *Settings* screen.

The following parameters can be changed in the *Settings* screen:

- **Display contrast**
Two settings are available to adjust the display contrast: dark (0) and bright (1).
- **Cursor speed**
The speed with which the cursor moves over the screen can be adjusted in steps of 10 in the range from 50 to 200.
- **Language**
Three languages can be selected for screen display: Italian (0), English (1) and German (2).
- **Def. Ratio Plasma/Blood**
This parameter sets the percentage share of plasma flow to blood flow during the separation of plasma. The setting is performed in steps of 1 % in the range from 10 % to 40 %. The default setting is 20 %.
As the plasma/blood ratio is relevant to patient safety, its change must be confirmed.
- **Def. PPL Threshold**
This parameter sets the limiting value for the automatic plasma flow adaptation during therapy. The setting is performed in steps of 5 mmHg in the range from -20 to 120 mmHg. The default setting is 20 mmHg.
- **Def. Ratio Dialysate/Plasma**
This parameter sets the ratio of the dialysis fluid flow in relationship to the plasma flow during therapy and reinfusion. The setting is performed in steps of 1 in the range from 2 to 4. The default setting is 2.
As the dialysate/plasma ratio is relevant to patient safety, its change must be confirmed.
- **Def. Plasma Reinfusion Flow**
This parameter sets the default value for the Return Flow (plasma reinfusion flow). After selecting a new therapy, Return Flow is set to this default value. The setting is performed in the range of 10 to 50 ml/min. The first default is 30 ml/min.
- **Date**
Day, month and year are set successively.
- **Time**
Hours and minutes are set successively.

If a parameter is relevant to patient safety, the currently set value is shown in the *Setting* window above the setting range (Fig. 3-7, ①). In addition, the LEDs above the *OK* key blink.

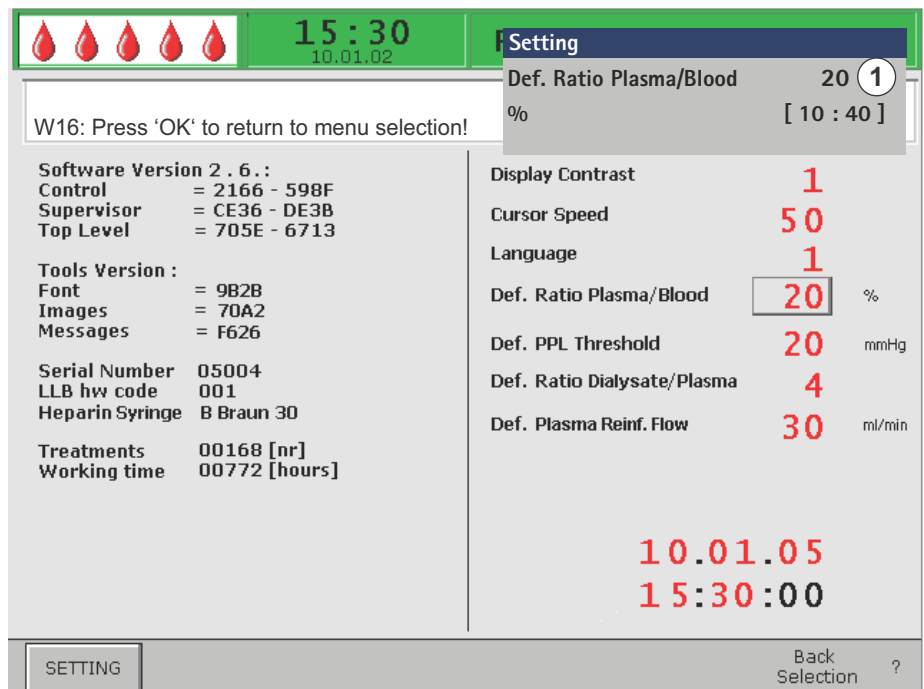

Fig. 3-7 Settings screen - selecting a safety relevant parameter

The modification of the following parameters must be confirmed with the *OK* key since they are relevant to patient safety:

- Def. Ratio Plasma/Blood
- Def. Ratio Dialysate/Plasma.



1. To terminate *Settings* screen, select *Back Selection* item (Fig. 3-8, ①) in menu bar and press *Enter* key.

↳ The previous screen (e. g. start screen) reappears.

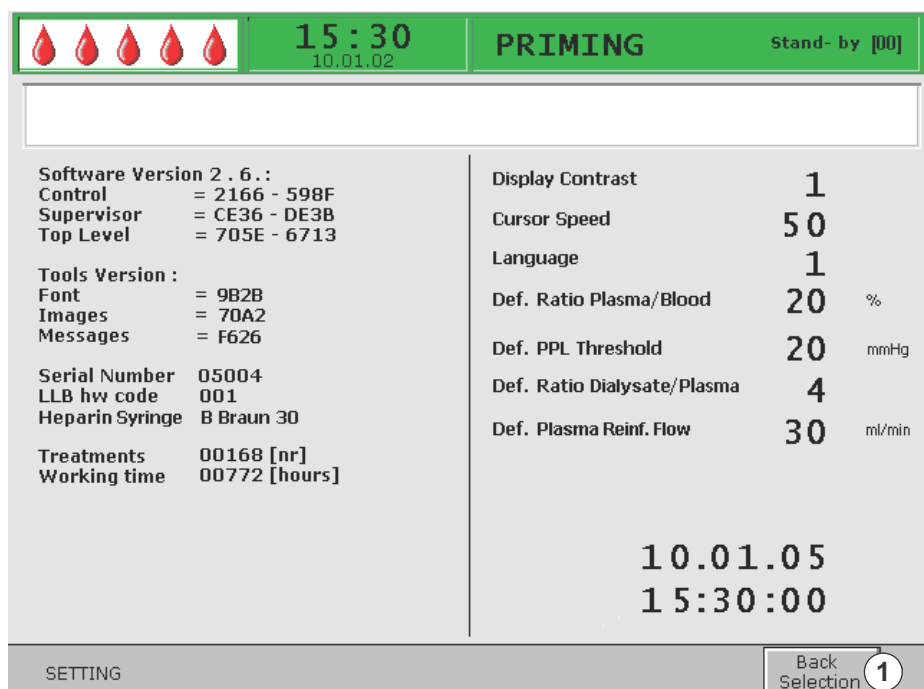

Fig. 3-8 Terminating the Settings screen

Table of contents

4	Preparing the Machine for Operation.....	63
4.1	Switching On and Initial Tests.....	64
4.2	Preparing the Solutions.....	66
4.3	Installing the Bags.....	68
4.4	Installing the H.E.L.P. Futura Set.....	69

4 Preparing the Machine for Operation

WARNING!

Safety air detector (SAD) not active! Danger of air embolism!

- Do not connect the patient out of therapy.
 - Out of therapy it is not allowed to use the pumps for infusion (e. g. saline solution).
-

WARNING!

Loss of blood or damage of blood by temperature, pressure or wrong composition of dialysis fluid!

- Ensure that the patient will only be connected in therapy phase.
-

CAUTION!

Risk of electric shock or machine damage if fluid enters the machine!

- Ensure that no fluid enters the machine.
 - Do not wipe the surface too moistly.
 - Only use appropriate cleaning agents.
-

NOTICE!

To prevent possible filter ruptures and line damages, prepare the machine at treatment site. Avoid to transport the machine when fully prepared for treatment!



If Ecoflac containers are used, there is no break seal. Observe the instruction leaflet!

4.1 Switching On and Initial Tests

Switching On the Machine

1. Ensure that brakes are applied to all machine casters.
2. Ensure that the pump roller marked with a yellow point is installed in plasma/buffer pump. Interchange rollers accordingly, if necessary.
3. Press power switch (On/Off switch) on rear side of machine (Fig. 4-1, ①).
 - ↖ The machine switches from Off to On status and self tests are initiated.



Fig. 4-1 Power switch on rear side of machine



While the machine is carrying out automatic tests, no disposables (solution bags, lines) must be installed at the machine.

Ensure that the load cell is not equipped with solutions and the pressure transducers are not screwed to the respective connections.

Preparations for therapy may only start when all self tests are performed successfully.

Hardware Self Tests

After switching on, the machine automatically performs a series of hardware self tests in order to check all control functions relevant to the safety of the machine. The different acoustic signals of the machine and the functioning of the LEDs are also tested.

The *Selftest* screen shows the controller tests on the left side (Fig. 4-2, ①) and the supervisor tests on the right side (②). During self tests, the *Retest* menu item (③) blinks.

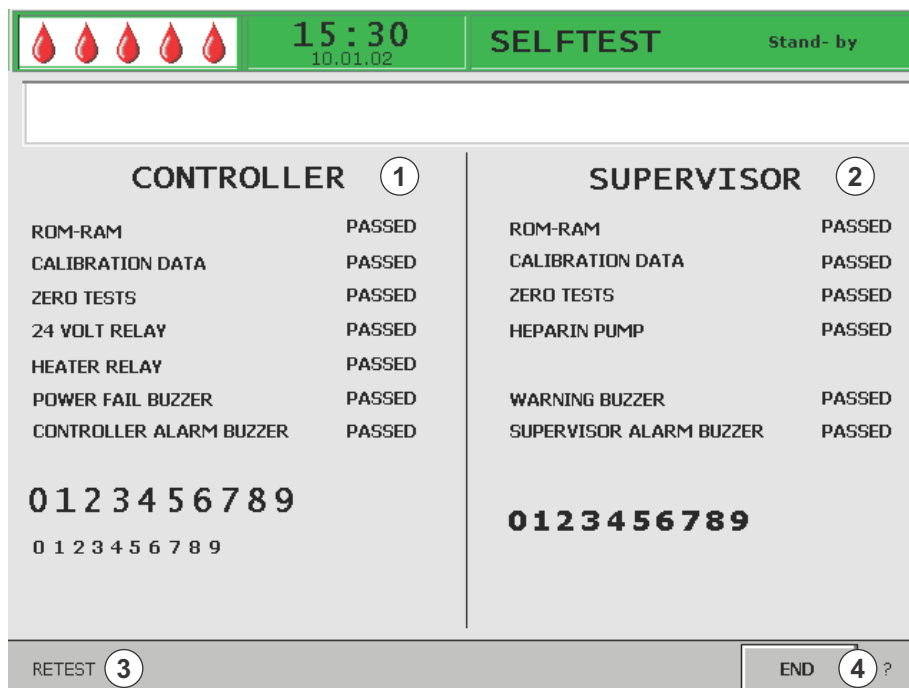

4

Fig. 4-2 Selftest screen

Positive self test:

- All tested positions are marked with “PASSED”. All three rows of numbers (0 1 2 3 4 5 6 7 8 9) are completely presented in the correct sequence and in the three fonts available at the machine.
- After a positive self test, the *END* menu item (④) is automatically activated. Press the *Enter* key to change to the start screen.

Negative self test:

- The affected positions are marked with “Failed” and/or the rows of numbers are not in the correct sequence or incomplete.
- After a negative self test, the *RETEST* menu item (③) is automatically activated. Press the *Enter* key to restart the test.

More information about the self tests are indicated in section 9.1 Self Tests (119).

Activities

1. Ensure that you hear four different alarm signals during self test.
2. Ensure that you see three rows of figures from 0 to 9 (see Fig. 4-2).
3. Ensure that LEDs next to screen flash.
4. When *END* item is selected in menu bar (after successful self test), press *Enter* key.
 - ↳ The start screen is displayed.

The preparation of solutions as well as the set up for operation can now begin as described in the following sections.

4.2 Preparing the Solutions

⚠ WARNING!

Risk to patient due to incorrect composition of fluids!

- Ensure that the correct fluids are provided for the intended therapy.
- Only use fluids whose printed use-by date has not expired.
- Only use originally closed and intact fluid bags.
- Observe storage information on bags.

H.E.L.P. 0.9 % NaCl, Physiological Saline Solution

1. Remove outer packaging of saline bag.
2. Fill a syringe with 1.5 ml heparin (5000 IU/ml).
3. Remove cannula from syringe.
4. Remove screw cap from one of the Luer-lock connectors of the bag and insert syringe.
5. Break seal of the bag.
6. Inject 1.5 ml heparin into saline bag.



Fig. 4-3 Preparing the saline solution bag

7. Carefully mix heparin with saline solution.
8. Prepare second bag in same manner.

H.E.L.P. BicEL, Bicarbonate Solution

1. Remove outer packing from bag.
2. Place bag on a firm base and press smaller chamber of the bag with both hands until seal seam between the two chambers is opened over its full length.
3. Move bag several times back and forth so that solutions are well mixed.



Fig. 4-4 Preparing the bicarbonate solution bag

4. Prepare other bag accordingly.



If the ready-to-use BicEL solution is not used immediately after mixing, use of the solution within 24 hours is in the responsibility of the user.

Acetate Buffer Solution

1. Remove outer packaging of acetate buffer bag.
2. Fill a syringe with 40 ml H.E.L.P. heparin sodium solution for extracorporeal application.
3. Remove cannula from syringe.
4. Remove screw cap from Luer-lock connector of the acetate buffer bag and insert syringe.
5. Break seal.
6. Inject 40 ml H.E.L.P. heparin sodium solution into 4-l-acetate bag.



Fig. 4-5 Preparing the acetate buffer solution bag

7. Carefully mix H.E.L.P. heparin sodium solution with acetate buffer.
8. Mark prepared bag with the label provided in H.E.L.P. heparin packaging to avoid repeated injection.

4.3 Installing the Bags

Physiological Saline Solution/Empty Bag

Hang following bags on IV-pole:

1. one 5 l empty bag with connectors upturned,
2. one prepared 3 l bag with physiological saline solution,
3. one 500 ml and one 1500 ml bag with physiological saline solution for reinfusion.



Fig. 4-6 Bags on IV-pole

Physiological Saline Solution/Dialysis Fluid/Drain Bag

Hang following bags on load cell:

1. second prepared 3 l bag with physiological saline solution
2. two prepared BicEL bags (dialysis fluid)
3. the drain bags after closing large clamps



Fig. 4-7 Bags on load cell



Acetate buffer and dialysis fluid should have room temperature before priming. Cold solutions can impact pump function and may cause a failure of pressurization test. During treatment cold solutions may decrease the efficacy of the treatment.

4.4 Installing the H.E.L.P. Futura Set

⚠ WARNING!

Risk to patient due to cross infection!

- Use disposables only once.

Setting-Up the H.E.L.P. Futura Kit

1. Place plastic plate of H.E.L.P. Futura kit onto lower support on machine (Fig. 4-8, ①).



Fig. 4-8 Attaching the H.E.L.P. Futura kit

2. Press plate against front of machine and secure with upper rotary attachment knob (Fig. 4-8, ②).
3. Retighten all connections of H.E.L.P. Futura kit.

⚠ CAUTION!

Risk to patient due to blood loss when using a faulty blood line system!

- Ensure that the blood line system and pump segments are not damaged at the insertion.
- Ensure that the pump segment is placed in the backmost position of the pump housing.
- When inserting the pump segments, do not rotate the rollers against a drag.
- If the blood line system has been damaged through the insertion, replace it by a new one.

4. Place pump segment of ultrafiltration line into ultrafiltration pump (white marking on left, Fig. 4-9, ①).

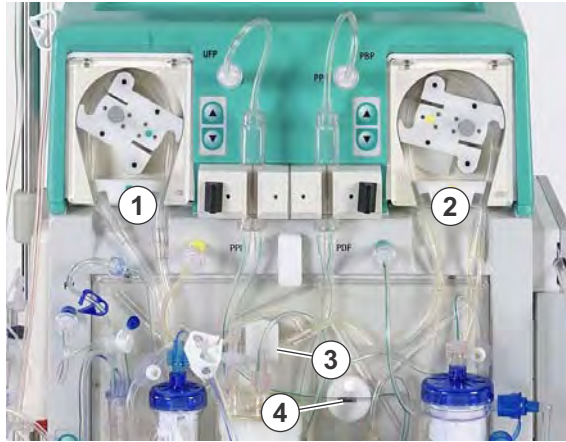

Fig. 4-9 Installing the pump segments

5. Place pump segments of plasma and buffer line (marked brown and yellow) successively into plasma/buffer pump (Fig. 4-9, ②).
The Y-piece connecting plasma and buffer line must be located at right side (outlet) of plasma/buffer pump.
6. Check that pump segments are inserted in correct orientation (see arrows on pump housings).
7. Insert plasma line, coming from plasma filter, into blood leak detector (BLD, Fig. 4-9, ③).
8. Firmly insert filtarte line to heparin adsorber into heparin adsorber clamp (HAK, Fig. 4-9, ④).
9. Place precipitate chamber and heparin adsorber chamber into corresponding holder (as shown in Fig. 4-10, ①) and lock in place by turning black locks.



Fig. 4-10 Installing the chambers

10. Screw on the four pressure transducers (Fig. 4-10, ②).
11. Check that venous chamber is placed in the holder at the kit and screw on venous pressure transducer (Fig. 4-10, ③).

12. Place venous line into safety air detector (SAD, Fig. 4-11, ①) and into tubing clamp (SAK, ②).

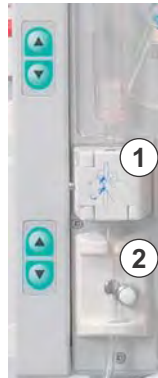

Fig. 4-11 Installing the venous line

13. Connect venous line to 5 l empty bag hanging on IV-pole.
14. Connect buffer line to prepared saline bag on load cell (Fig. 4-12).



Fig. 4-12 Connecting the buffer and ultrafiltrate lines

15. Connect ultrafiltrate lines to the three drain bags.
16. Insert buffer line into the holder provided on load cell.

Setting-Up the Arterial Line

1. Place arterial chamber into the holder (Fig. 4-13, ①).

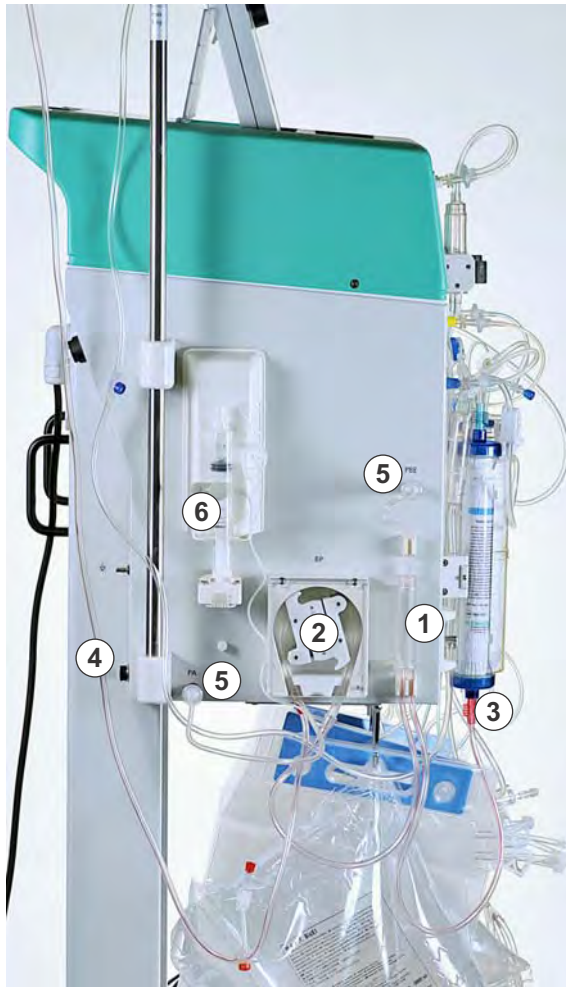

Fig. 4-13 Setting-up the arterial line

2. Place pump segment of arterial line with red marking on left side into blood pump (Fig. 4-13, ②).
3. Connect arterial feeder line to inlet of plasma filter (Fig. 4-13, ③).
4. Connect arterial line (Fig. 4-13, ④) to the prepared saline bag hanging on IV-pole.
5. Screw on the two pressure transducers (Fig. 4-13, ⑤).
6. Fill a syringe (30 ml Omnifix[®] Perfusor syringe) with heparin saline mixture and connect it with heparin line.



Recommendation: 16 ml 0.9% NaCl + 4 ml heparin (5000 IU/ml) corresponding to a concentration of 1000 IU heparin/ml.

7. Vent heparin line manually up to T-piece. Make sure that no air bubbles are left in the line.
8. Mount syringe on holder of heparin pump (Fig. 4-13, ⑥).

Setting-Up the Dialysate Line

1. Insert warming bag into plate warmer (Fig. 4-14, ①), using the holes provided in bag.

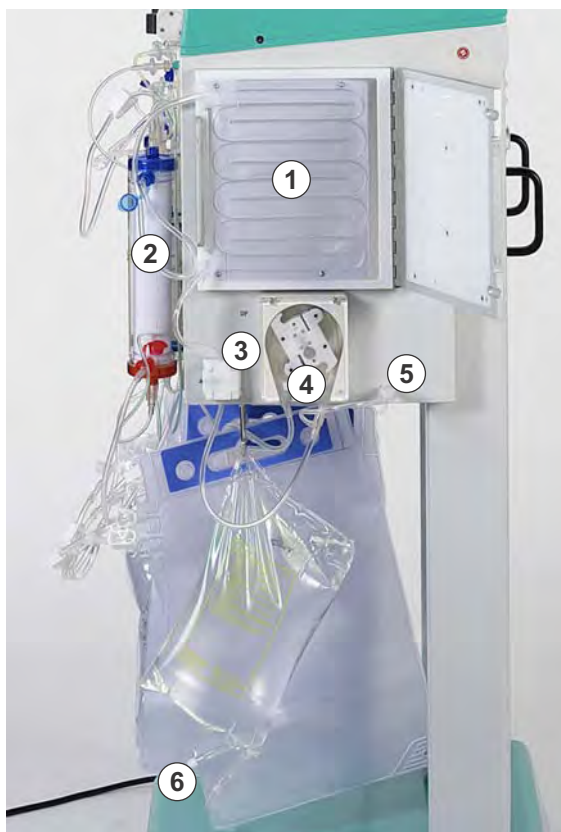

Fig. 4-14 Setting-up the dialysate line

2. Connect blue inflow line to dialyzer (Fig. 4-14, ②).



Connect red connector to red coupling and blue connector to blue coupling! Make sure that the Hansen connector is firmly seated.

3. Place blue inflow line into dialysate air detector (DAD, Fig. 4-14, ③).
4. Insert pump segment of dialysate line into dialysate pump (Fig. 4-14, ④) with blue marking on left side.
5. Screw on the pressure transducer (Fig. 4-14, ⑤).
6. Connect distributor of dialysate line to prepared dialysate bag (Fig. 4-14, ⑥) and break seal.
7. Insert dialysate inlet line into holder provided at load cell.

Table of contents

5 Priming and Rinsing.....77

5.1 Automatic Priming and Rinsing..... 77

5.2 Parameter Setting 80

5.2.1 Parameter Setting in the Main Parameter Screen 80

5.2.2 Parameter Setting in the Parameter Overview
Screen 82

5.2.3 Parameter Setting in the Flow Scheme Screen 85

5.2.4 Additional Functions 85

5 Priming and Rinsing

5.1 Automatic Priming and Rinsing

After closing the *Selftest* screen (after a successful self test) by confirming the *End* item in the menu bar, the start screen (Fig. 5-1) appears. On the start screen, the message *Press enter key to start* is displayed blinking and in red.



Fig. 5-1 Start screen



1. If machine has been prepared as described in previous chapter, press *Enter* key to start priming and rinsing phase.

- ↪ The *Main Parameter* screen is displayed by default. The status bar indicates the current phase (*Priming*) and the current step of the phase (*Stand-by [00]*, Fig. 5-2, ①). In the menu bar, the cursor is located on the *Start Priming* item (③). The label changes between black and gray (blinking) to indicate that an input is expected from the user.
- ↪ The *Warning* window appears indicating the message *W18: Break seals and open all clamps !* (②).

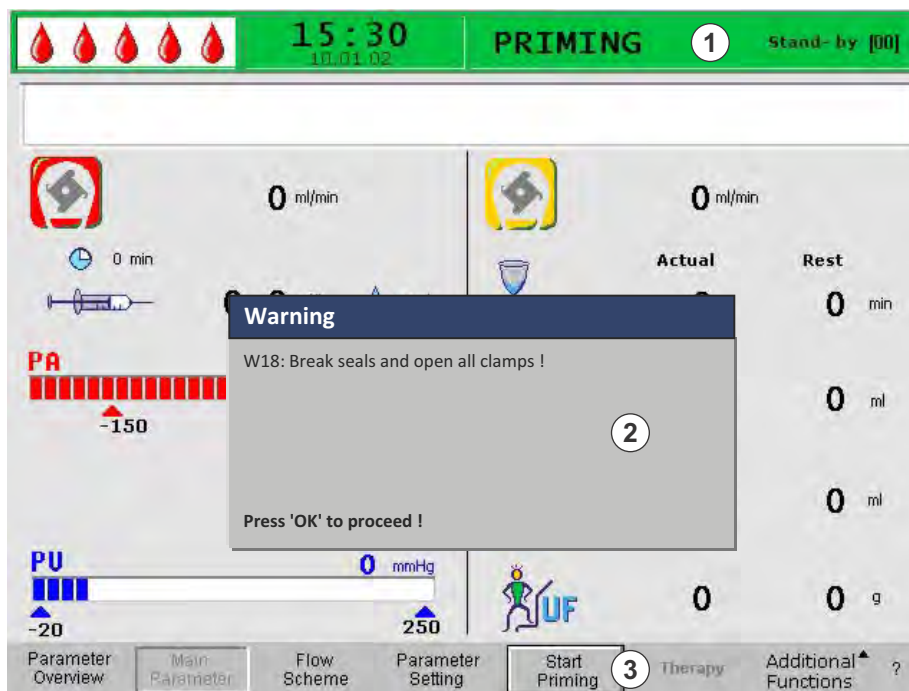

Fig. 5-2 Main Parameter screen - Start Priming

Checking the System and Starting Priming

1. Ensure that all connections between line system and filters have been established.
2. Tighten all screw locks as well as Hansen connectors again.
3. Ensure that lines are not kinked.
4. Ensure that electrolyte solution is mixed with bicarbonate solution and sealing seam is completely open.
5. Ensure that break seals of saline bags on IV-pole and load cell are open.
6. Ensure that break seals of dialysis fluid bags are open.
7. Ensure that clamps at unused ports of empty bags are closed.
8. Press *OK* key to continue.
 - ☞ The cursor is located at the blinking *Start Priming* item in the menu bar.
9. Press *Enter* key to start priming with automatic filling of blood side.
 - ☞ The message *W01: Plasma pump starts after pressurizing blood side* appears in the Alarm/Note line of the screen.

Automatic Filling of Blood Side

During automatic filling, the arterial line, the plasma filter and the venous line are rinsed and filled by default with 600 ml saline solution.

Step 1 and 2

The arterial line, the plasma filter and the venous line are filled. The preset blood flow rate is 150 ml/min.

Step 3

The tubing clamp (SAK) opens and then closes again and the level of the arterial chamber is set accordingly. This vents the plasma filter.

Step 4

The plasma/buffer pump starts and the precipitate filter is filled. This step is completed when the level monitoring of the precipitate chamber (PCLD) detects fluid and the balance test 1 has been completed.

Step 5

Filling the heparin adsorber chamber.

Step 6

Leakage test of the heparin adsorber clamp.

Step 7

The heparin adsorber clamp (HAK) opens. The level detection in the heparin adsorber chamber and the venting of the connection line to the heparin adsorber are performed. This step includes the filling of the dialyzer on the plasma side.

Step 8

The *Warning* window prompts with the message *W04: Turn dialyzer (blue side down) !*.



Turn the dialyzer by 180°, with blue side pointing downward. Press the *OK* key to continue.

Step 9

The dialysate side of the dialyzer is filled. The balance test 2, DAD test, heating test, venous pressure test as well as ultrafiltration pump test are performed in this step.

Step 10

The level of the venous chamber is set.

Step 11

This step is completed when the minimum rinsing volume of 2400 ml is reached. The message *W14: Rinsing completed. For further rinsing set new value !* is displayed in the *Warning* window.

Press the *OK* key to confirm reaching of minimum rinsing volume.

If minimum rinsing volume is sufficient, you can now start with therapy.

Step 12

Optional rinsing

This step allows rinsing of the system beyond the minimum rinsing volume.

If you wish to increase the rinsing volume:

1. Select *Parameter Setting* menu item in menu bar.
2. Select *Rinsing volume* parameter and change this parameter. Rinsing volume can be set to a value of up to 10 l.



When increasing the rinsing volume over 2400 ml, make sure that sufficient saline solution is available. If required, change the bags on the load cell and on the IV-pole.

3. Select *Start Priming* menu item in menu bar.

↵ When the rinsing volume has been reached, all pumps stop automatically.

Additional Manual Rinsing of Blood Side

If you wish to increase the rinsing volume in the blood circuit:



1. Press *Start/Stop* key to start blood pump.
2. When sufficiently rinsed the blood side, press *Start/Stop* key again to finish rinsing.



When increasing the rinsing volume, make sure that sufficient saline solution is available. If required, change the bags on the load cell and on the IV-pole.

5

⚠ WARNING!

Risk to patient due to air infusion!

- After rinsing, make sure that all air is removed before connecting to the patient.

5.2 Parameter Setting

5.2.1 Parameter Setting in the Main Parameter Screen

For detailed information about setting of parameters, see section 2.6 Parameter Setting (40).

After selecting the *Parameter Setting* item in the menu bar, all parameters which can be changed are displayed in red.

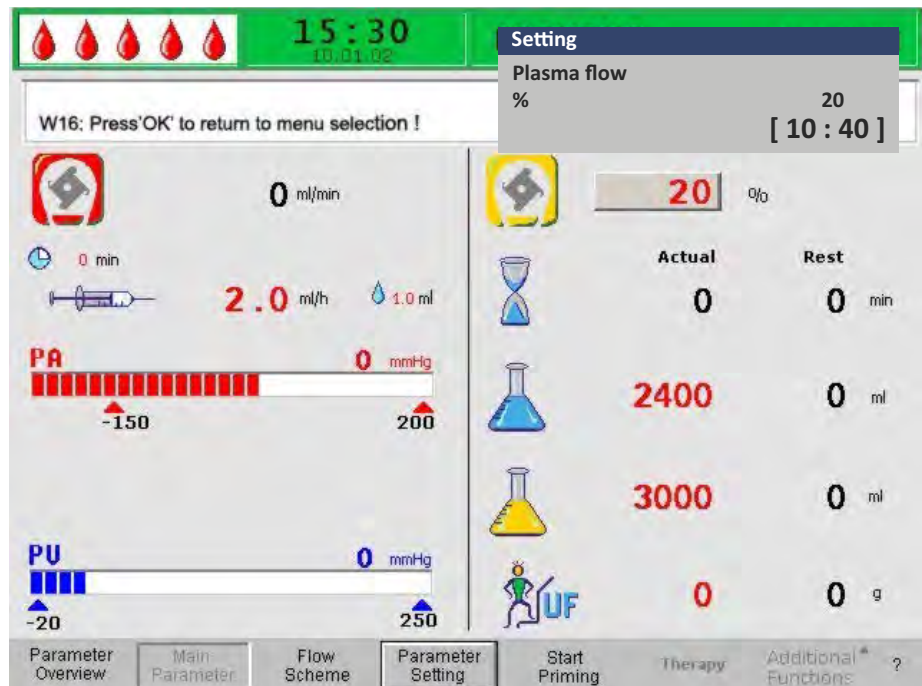





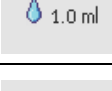
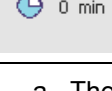

Fig. 5-3 Parameter selection in *Main Parameter* screen

The following parameters can be set in the priming phase:

Icon	Parameter	Default	Range	Step Size
	Plasma flow [%] ^a	20	10 – 40	1
	Rinsing volume [ml] ^b	2400	2400 – 10000	100
	Plasma volume [ml]	300	100 – 6000	50
	Patient balance [g] ^c	0	-600 – 0	50
	Heparin flow [ml/h]	2	0 – 10	0.5
	Heparin bolus [ml]	1	0 – 10	0.5
	Autostop Heparin [min] ^d	0	0 – 60	5

- a. The plasma flow is set in % of blood flow and displayed in ml/min. The plasma flow is limited to a maximum of 40 % of the blood flow and 50 ml/min at the highest. If the blood flow is changed manually, the plasma flow is automatically changed according to the set ratio.
- b. The rinsing volume can be increased beyond the set minimum rinsing volume of 2400 ml.
- c. Patient balance is not an ultrafiltration within the context of a dialysis. This option provides the possibility of additionally removing the existing physiological saline solution or to balance the physiological saline solution required for blood reinfusion. When setting a balance, the hematocrit value of the blood is changed which may complicate the separation of plasma sometimes.
- d. Autostop heparin indicates how long before the end of the therapy the heparin administration is stopped. If the therapy time is increased after the heparin pump is switched off, the heparin pump starts again automatically.

The changing of the following parameters must be confirmed with the *OK* key since they are relevant to patient safety:

- Plasma flow
- Plasma volume
- Balance
- Heparin flow
- Heparin bolus

⚠ CAUTION!

Risk to patient due to insufficient or too high heparinization!

- With a plasma volume > 4000 ml, the heparin adsorber must be changed in order to keep the required capacity.
- Use only 30 ml Omnifix® Luer Lock syringes from B. Braun Melsungen AG as the heparin syringe pump is calibrated only for this type of syringe.

⚠ CAUTION!

Risk to patient due to hypotension in rare cases!

- Change the therapy as prescribed by the supervising physician.



With a plasma volume > 4000 ml, the acetate buffer bag and the dialysis fluid bags must be changed.

5.2.2 Parameter Setting in the Parameter Overview Screen

For detailed information about setting of parameters, see section 2.6 Parameter Setting (40).

After selecting the *Parameter Setting* item in the menu bar, all parameters which can be changed are displayed in red. For a better overview, blood flow (red) and plasma flow (yellow) are marked with colored arrows.



Fig. 5-4 Parameter selection in *Parameter Overview* screen

The following parameters can be set in the priming and rinsing phase:

- Plasma volume [ml]
- Patient balance [g]
- Plasma flow [%]
- Heparin flow [ml/h]
- Heparin bolus [ml]
- Autostop heparin [min]
- Temperature [°C]
- Rinsing volume [ml]
- PA MIN [mmHg]
- PA MAX [mmHg]
- PV MIN [mmHg]
- PV MAX [mmHg]
- PPL MIN [mmHg]
- TMP MAX [mmHg]
- PPF MIN [mmHg]
- PDF MIN [mmHg]
- PDF MAX [mmHg]
- PDPA MAX [mmHg]
- PPL Threshold [mmHg]
- Ratio Dialysate/Plasma

In addition to the parameters listed in section 5.2.1 Parameter Setting in the Main Parameter Screen (80), the following parameters can be entered:

Parameter	Default	Range	Step Size
Temperature [°C]	39	34 – 40	0.5
PA MIN [mmHg]	-150	-350 – 80	10
PA MAX [mmHg]	100	0 – 200	10
PV MIN [mmHg]	20	10 – 40	5
PV MAX [mmHg]	40	20 – 100	5
PPL MIN [mmHg]	-10	-20 – 10	1
TMP MAX [mmHg]	70	20 - 200	10
PPF MIN [mmHg]	-20	-50 – 50	5
PDF MIN [mmHg]	-50	-50 – 0	5
PDF MAX [mmHg]	350	10 – 400	10
PDPA MAX [mmHg]	150	50 – 350	10

Parameter	Default	Range	Step Size
PPL Threshold [mmHg]	20	-10 – 120	5
Ratio Dialysate/Plasma	2	2 – 6	1

The changing of the following parameters must be confirmed with the *OK* key since they are relevant to patient safety:

- Plasma flow
- Plasma volume
- Balance
- Heparin flow
- Heparin bolus
- PA MIN
- PA MAX
- PV MIN
- PV MAX
- Ratio Dialysate/Plasma

 **WARNING!**

Risk to patient due to blood loss since increasing the PV MIN window elevates the likelihood of an unrecognised removal of venous access!

- Do not cover the venous access.
- Keep the patient under continuous surveillance.

5.2.3 Parameter Setting in the Flow Scheme Screen

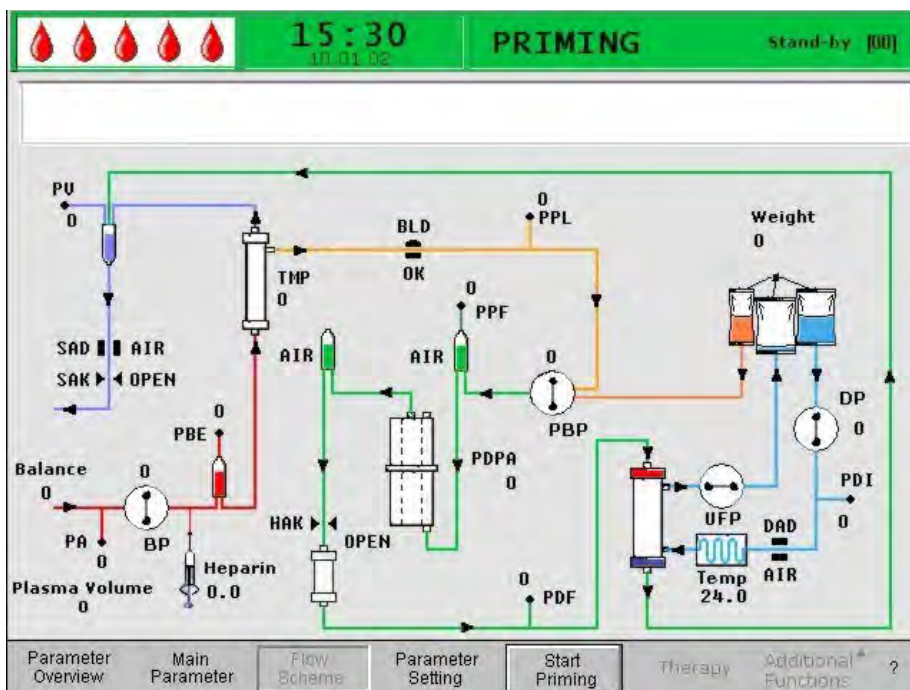

Fig. 5-5 Flow Scheme screen in the priming phase

After selecting the *Parameter Setting* item in the menu bar, the screen changes to the setting screen of the *Parameter Overview*. Here, all settings can be performed as described in section 5.2.2 Parameter Setting in the Parameter Overview Screen (82).

5.2.4 Additional Functions

During priming and rinsing, the *Additional Functions* item is not active in the menu bar.

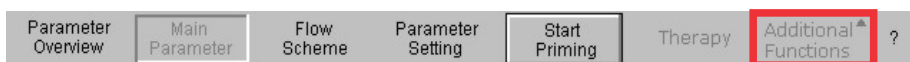

Fig. 5-6 Menu bar during priming and rinsing

New Therapy

To cancel the priming and rinsing phase and return to the start screen, switch off the machine and switch it on again while pressing the *Alarm* key.

5

Table of contents

6	Therapy	89
6.1	Start of Therapy	89
6.2	End of Therapy	93
6.3	Parameter Setting	94
6.3.1	Parameter Setting in the Main Parameter Screen	94
6.3.2	Parameter Setting in the Parameter Overview Screen	95
6.3.3	Parameter Setting in the Flow Scheme Screen	97
6.4	Premature Termination of Therapy	98
6.5	Additional Functions	98

6 Therapy

⚠ WARNING!

Risk to patient due to infection as a result of filter breaks!

- In case of filter breaks, replace the filter during therapy.

For filter replacement, see section 9.4 Problem Correction (153).

⚠ CAUTION!

Risk to patient in case of acetate buffer bag leakage!

- Loss of acetate buffer to the environment leads to a lower efficacy of therapy and may cause a wrong ultrafiltration.
- Acetate buffer in the environment can harm user and patient, mainly if mixed with disinfection fluids such as hypochloride. Gas formation! Open the window and evacuate the room.

6

6.1 Start of Therapy

Starting the Therapy



Changing to the therapy phase is possible only when the minimum rinsing volume of 2400 ml has been reached.



1. After completion of priming and rinsing phase, select *Therapy* menu item in menu bar and press *Enter* key.

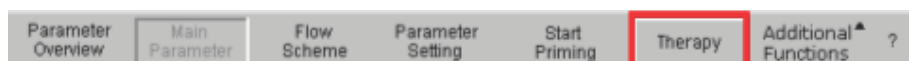

Fig. 6-1 *Therapy* menu item in the menu bar

- ↗ The *Warning* window appears with the message *W32: Activate therapy mode ?*.



2. Press *OK* key to confirm message.

- ↗ The *Main Parameter* screen is displayed indicating *THERAPY* in the status bar. In the menu bar, the *Start Therapy* menu item becomes active. The *Warning* window appears with the message *W15: Connect buffer, check if seal and clamp are open !*.

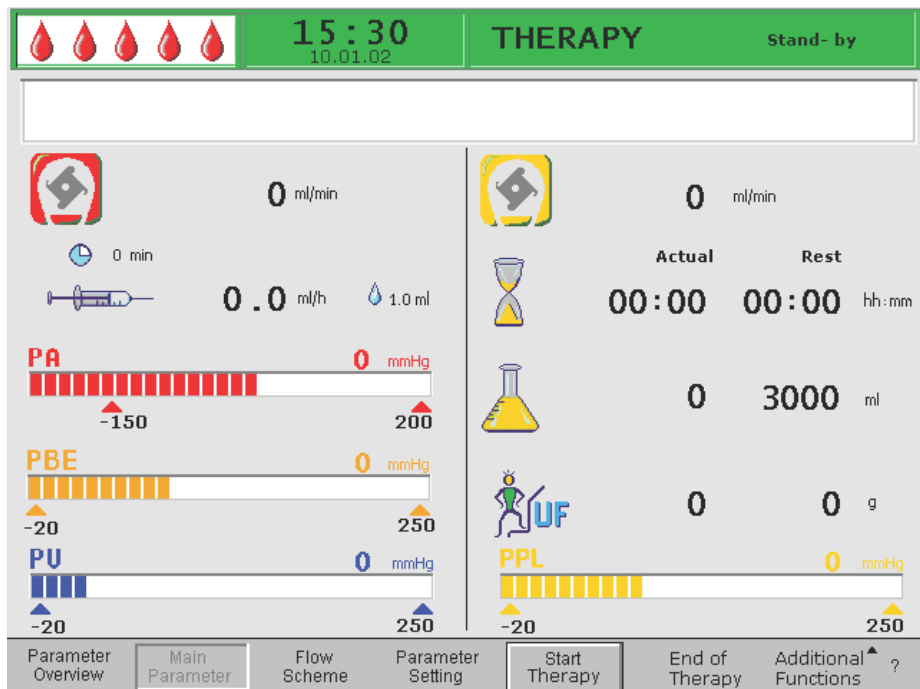

Fig. 6-2 Main Parameter screen in therapy

3. Exchange saline bag on load cell with prepared acetate buffer bag.
4. Remove venous line from empty bag on IV-pole and screw it to second connection of saline bag on IV-pole (next to arterial line).
5. Remove empty bag from IV-pole.
6. Remove clamps from bag and buffer line and make sure that all bag break seals are open.
7. Press **OK** key to confirm message in *Warning* window.
 - ☞ The machine is now ready for the therapy and the patient can be connected.
8. At this point at the latest, enter parameters required for therapy, such as plasma volume, heparin flow, heparin bolus, etc. (see section 2.6 Parameter Setting (40)).

Starting the Blood Circuit

1. Disconnect arterial line from physiological saline bag on IV-pole.
2. Connect arterial line to patient access for blood drawing.



The green and red LEDs above the *Start/Stop* key blink alternately to indicate that the blood pump can be started.



3. Press *Start/Stop* key to start blood pump.



4. If desired, adapt blood flow to existing pressure situation using + key and – key.



↳ The default setting of the blood flow is 40 ml/min.



5. When first traces of blood reach saline bag on IV-pole, press *Start/Stop* key to stop blood pump.

6. Connect venous line to patient access for blood return.



7. Press *Start/Stop* key to start blood pump and adapt blood flow to existing pressure conditions and tolerance of patient. Observe pressure limits displayed on monitor!



The patient can also be connected venovenous without phlebotomy but with volume substitution. Connect the patient's arterial line as well as the venous line to the patient's accesses for drawing blood and blood return, respectively. Fill the blood-side line system by pressing the *Start/Stop* key.

Starting the Plasma Circuit

1. Allow blood to circulate for a short period (approx. 2 minutes) until a spontaneous yellow coloring occurs in proximal part of plasma filter.

⚠ CAUTION!

Risk to patient due to hemolysis because of a high shear stress!

- Only start therapy as soon as enough plasma has been separated in the plasma compartment of the plasma filter to avoid hemolysis and to receive ideal plasma separation.
- Gradually increase first the blood flow and then the plasma flow.



2. Select *Start Therapy* menu item in menu bar and press *Enter* key.



Fig. 6-3 *Start Therapy* menu item in the menu bar



Plasma treatment begins.
The menu item text *Start Therapy* changes into *Stop Therapy*.



Fig. 6-4 *Stop Therapy* menu item in the menu bar

3. Gradually increase first blood flow rate to reach desired target value after 5 minutes.
4. Afterwards increase plasma flow step by step until a suitable value has been reached.

Rules for therapy to ensure a spontaneous separation of plasma:

- Blood flow should be between 80 ml/min and 120 ml/min.
- Plasma flow should be approximately 30 % of blood flow but should not exceed 35 ml/min.
- Changes of PPL and TMP must be taken into account when adjusting plasma flow!

The treatment is automatically monitored and terminated when the desired plasma volume has been reached.

The treatment can be interrupted at any time with the *Stop Therapy* menu item and switching to the reinfusion phase.



The therapy period is timed only while the plasma circuit is running.

6.2 End of Therapy

When the treated plasma volume is achieved, the machine switches to the stand-by mode. The blood circuit continues to circulate with the most recent blood flow rate selected. The cursor automatically points to the *End of Therapy* menu item in the menu bar (Fig. 6-5, ①).

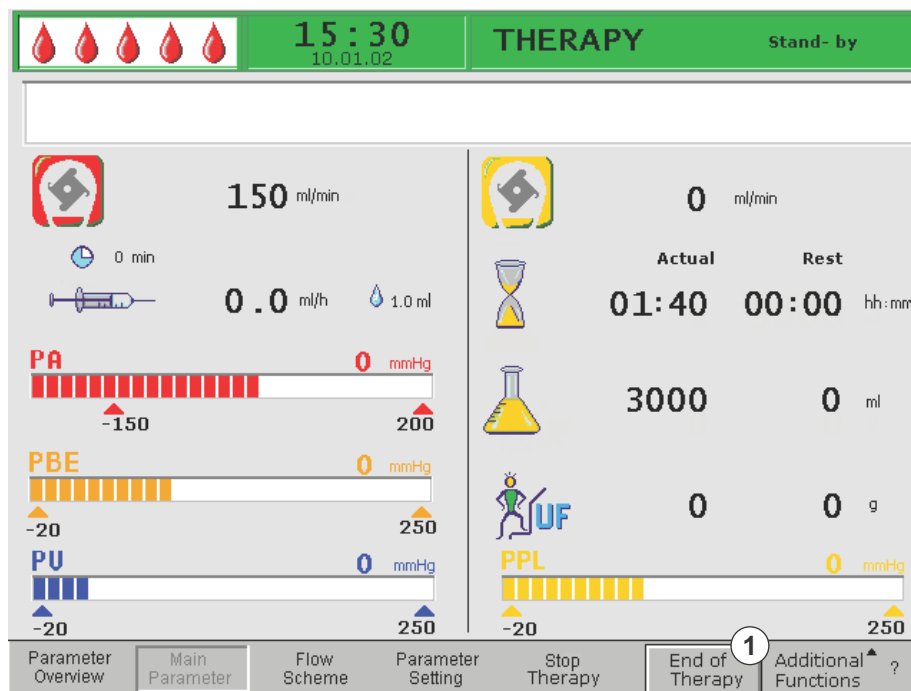

Fig. 6-5 Main Parameter screen with *End of Therapy* menu item



1. Press *Enter* key to finish therapy.

↳ The *Warning* window appears with the message *W35: Activate reinfusion ?*.



2. Press *OK* key to confirm message.

↳ The reinfusion phase is started.

⚠ CAUTION!

Risk to patient due to blood and/or plasma loss and subsequent blood pressure drop in case of a premature termination of therapy without reinfusion of plasma and/or blood volume!

- Substitute the missing volume. Apply an albumin solution as prescribed by the handling physician.
- Request the patient to drink more liquids than usual.

6.3 Parameter Setting

6.3.1 Parameter Setting in the Main Parameter Screen

For detailed information about setting of parameters, see section 2.6 Parameter Setting (40)

After selecting the *Parameter Setting* item in the menu bar, all parameters which can be changed are displayed in red.

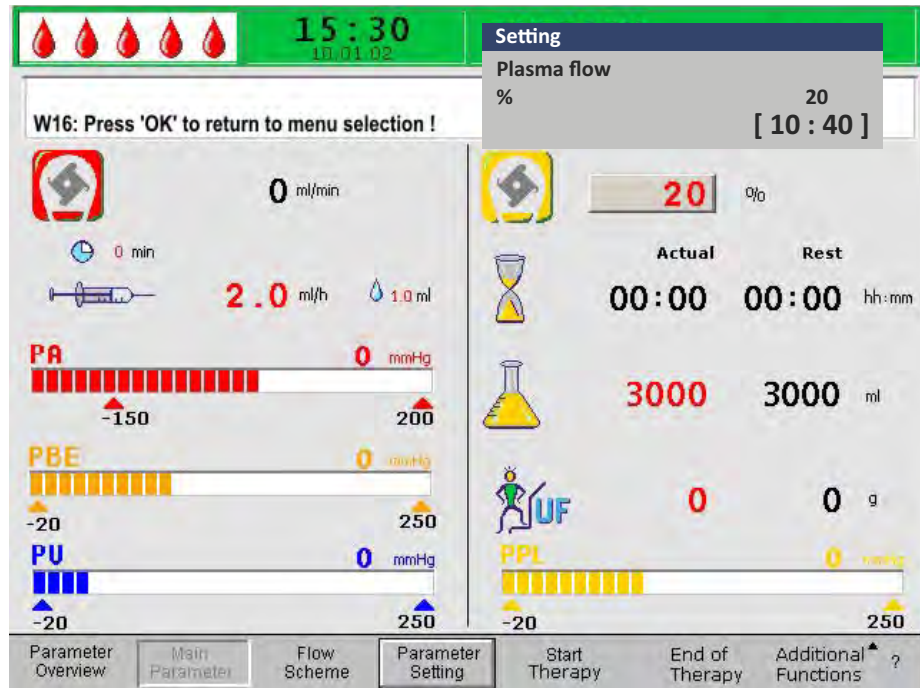

Fig. 6-6 Parameter selection in the *Main Parameter* screen

The following parameters can be set in the therapy phase:

Icon	Parameter
	Plasma flow [%]
	Plasma volume [ml]
	Patient balance [g]
	Heparin flow [ml/h]
	Heparin bolus [ml]
	Autostop Heparin [min]

The changing of the following parameters must be confirmed with the *OK* key since they are relevant to patient safety:

- Plasma flow
- Plasma volume
- Patient balance
- Heparin flow
- Heparin bolus

For more details about parameter setting values, see section 5.2.1 Parameter Setting in the Main Parameter Screen (80).

6.3.2 Parameter Setting in the Parameter Overview Screen

For detailed information about setting of parameters, see section 2.6 Parameter Setting (40)

After selecting the *Parameter Setting* item in the menu bar, all parameters which can be changed are displayed in red. For a better overview, blood flow (red) and plasma flow (yellow) are marked with colored arrows.

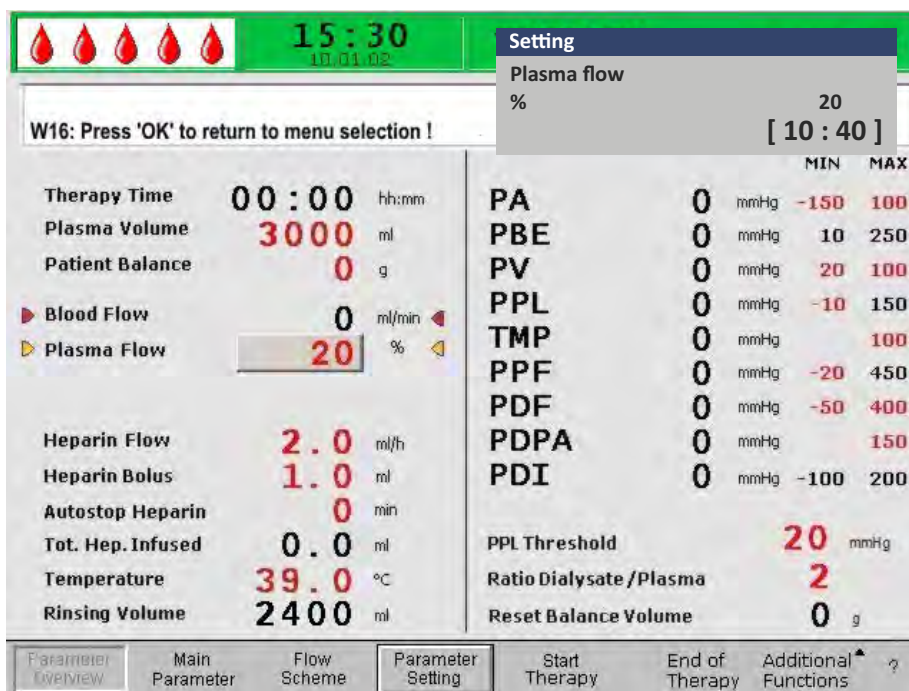

Fig. 6-7 Parameter selection in the *Parameter Overview* screen

The following parameters can be set in the therapy phase:

- Plasma volume [ml]
- Balance [g]
- Plasma flow [%]
- Heparin flow [ml/h]
- Heparin bolus [ml]
- Autostop heparin [min]
- Temperature [°C]
- PA MIN [mmHg]
- PA MAX [mmHg]
- PV MIN [mmHg]
- PV MAX [mmHg]
- PPL MIN [mmHg]
- TMP MAX [mmHg]
- PPF MIN [mmHg]
- PDF MIN [mmHg]
- PDF MAX [mmHg]
- PDPA MAX [mmHg]
- PPL Threshold [mmHg]
- Ratio Dialysate/Plasma

The changing of the following parameters must be confirmed with the *OK* key since they are relevant to patient safety:

- Plasma flow
- Plasma volume
- Balance
- Heparin flow
- Heparin bolus
- PA MIN
- PA MAX
- PV MIN
- PV MAX
- Ratio Dialysate/Plasma

 **WARNING!**

Risk to patient due to blood loss since increasing the PV MIN window elevates the likelihood of an unrecognized removal of venous access!

- Do not cover the venous access.
- Keep the patient under continuous surveillance.

For more details about parameter setting values, see section 5.2.2 Parameter Setting in the Parameter Overview Screen (82).

6.3.3 Parameter Setting in the Flow Scheme Screen

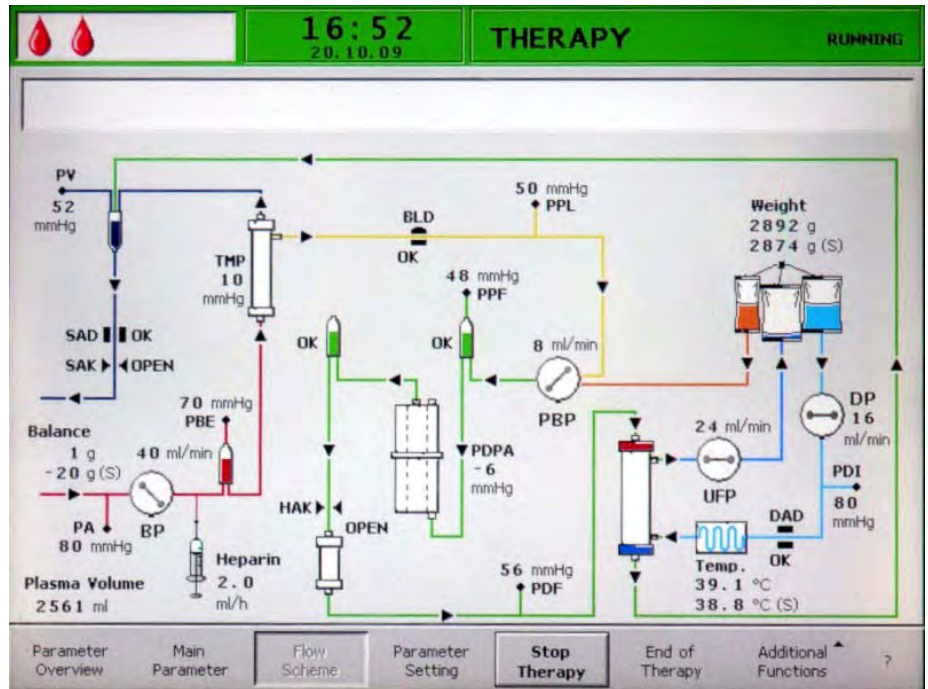

Fig. 6-8 Flow Scheme screen in the therapy phase

After selecting the *Parameter Setting* item in the menu bar, the screen changes to the setting screen of the *Parameter Overview*. Here, all settings can be performed as described in section 6.3.2 Parameter Setting in the Parameter Overview Screen (95).

6

6.4 Premature Termination of Therapy

The therapy can be terminated prematurely at any time:



1. Select *End of Therapy* menu item in menu bar and press *Enter* key.

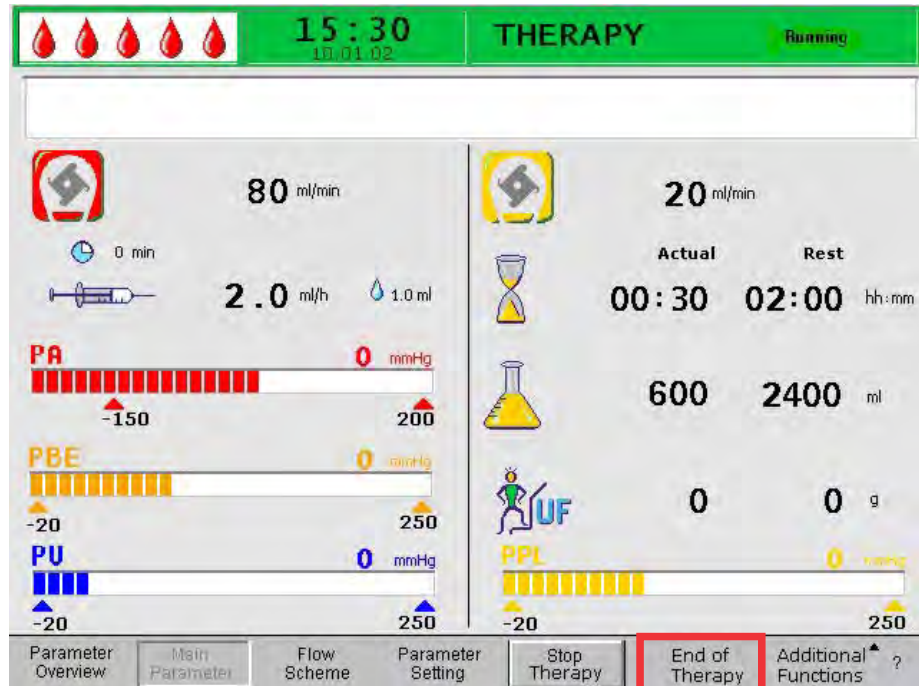

Fig. 6-9 Terminating the therapy

- ↳ After activating the *End of Therapy* command, the *Warning* window is displayed with the message: *W35: Activate reinfusion ?*.



2. Press *OK* key to confirm termination of therapy.

- ↳ The reinfusion phase is started (see next chapter, Reinfusion).

6.5 Additional Functions

From the *Main Parameter*, *Parameter Overview* and *Flow Scheme* screens, *Additional Functions* can be selected in the menu bar and activated by pressing the *Enter* key.

When *Additional Functions* is selected, a submenu with the following items is opened (see Fig. 6-10):

- *Stop bolus*
active only while heparin bolus is administered
- *Heparin bolus*
active during therapy
- *Balance Reset*
active only for improper balancing > 200 g (for a more detailed description, see section 9.4.1 Balance Reset (153))

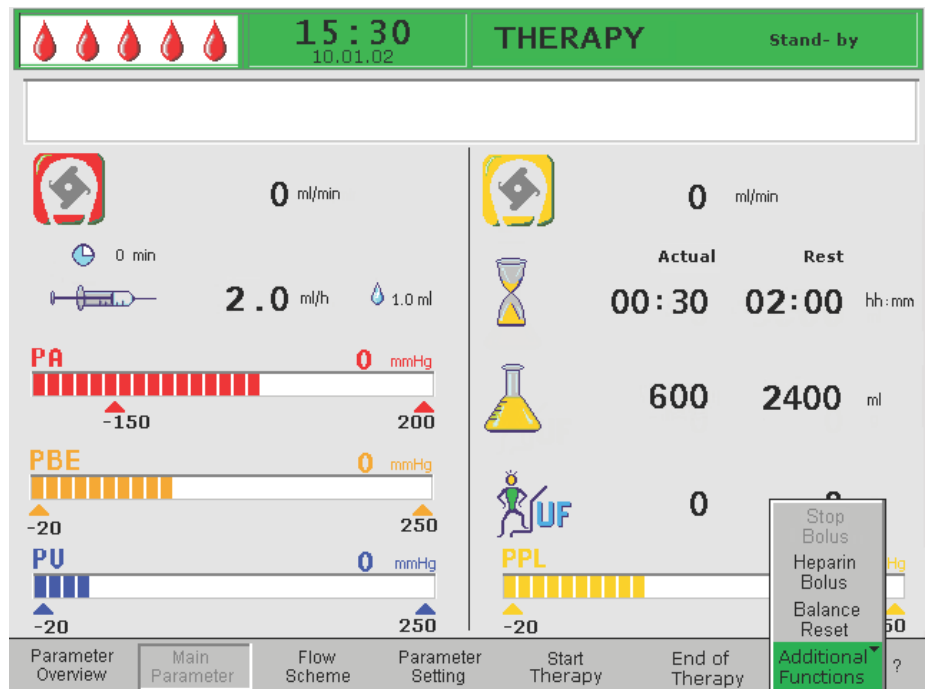

Fig. 6-10 Additional Functions menu in the therapy phase

Active menu items are shown in black labeling and inactive items in gray labeling. The selected active field has a green background.

⚠ WARNING!

Risk to patient due to impact on patient's fluid balance!

- Perform the balance reset only when you are sure that the balancing error was triggered by a leakage of the dialysis and/or waste bags and does not concern the patient.
- If you are not able to detect the root cause, stop therapy and call technical service.

Heparin Bolus



- To administer a heparin bolus during therapy, select *Heparin Bolus* menu item from *Additional Functions* submenu and press *Enter* key to confirm.
 - The *Warning* window is displayed with the message *W33: Heparin bolus ?*.



Fig. 6-11 Heparin bolus in the therapy phase



- Press *OK* key to confirm that a heparin bolus shall be administered. If you do not wish to administer a heparin bolus, wait for the *Warning* window to disappear after 5 seconds.
 - During heparin administration, the symbol of heparin bolus (drop) alternates between a large red drop and a small blue drop, and the *Stop Bolus* menu item in the submenu is active.

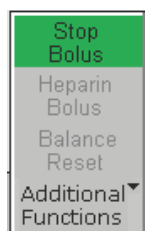

Fig. 6-12 *Stop Bolus* menu item in *Additional Functions* submenu



- The heparin bolus can be interrupted at any time by pressing the *Enter* key.
- After heparin administration, the *Stop Therapy* menu item is automatically reselected in the menu bar.



Fig. 6-13 *Stop Therapy* menu item selected in the menu bar

6

Table of contents

7	Reinfusion and Termination	103
7.1	Plasma Reinfusion	103
7.2	Blood Reinfusion.....	105
7.3	Terminating Treatment.....	106
7.4	Parameter Setting	107
7.4.1	Parameter Setting in the Main Parameter Screen	107
7.4.2	Parameter Setting in the Parameter Overview Screen	108
7.4.3	Parameter Setting in the Flow Scheme Screen	110
7.5	Additional Functions.....	110

7 Reinfusion and Termination

7.1 Plasma Reinfusion

After terminating the therapy as described in section 6.2 End of Therapy (93), the *Reinfusion* screen is displayed.

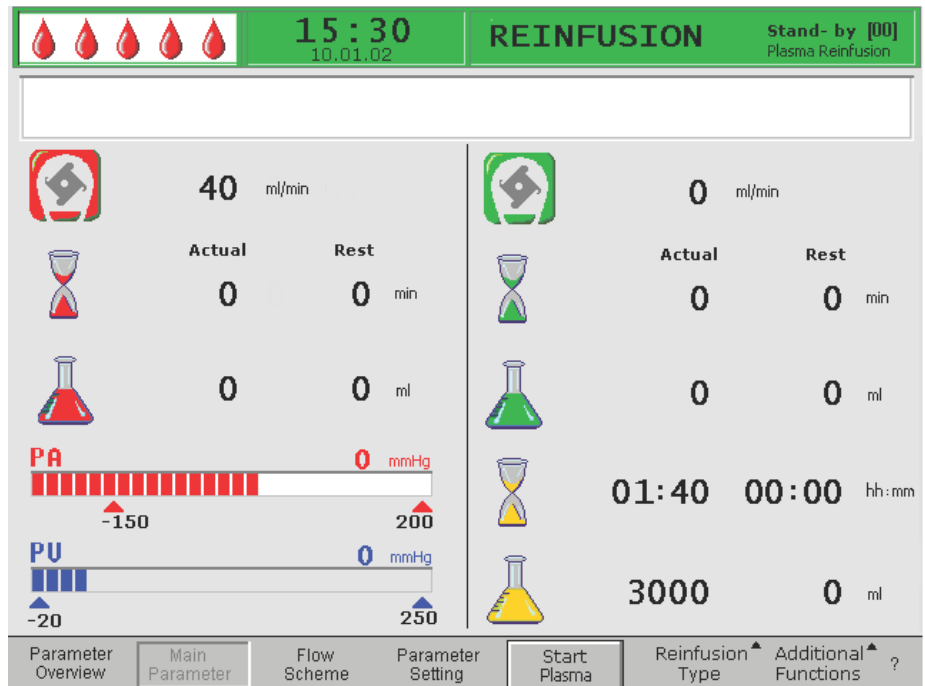

Fig. 7-1 Main Parameter screen in the reinfusion phase

After changing to the reinfusion phase, the blood flow is not stopped but set automatically to 30 ml/min.

The default setting of the plasma reinfusion volume is 400 ml.

The next steps for preparing the reinfusion are summarized in the *Warning* window that appears:

Warning

W11:

- 1) Connect reinfusion and buffer lines to saline solution!
- 2) Clamp plasma line at outlet of plasma filter !
- 3) Turn plasma and precipitate filters !
- 4) Turn heparin adsorber !

Press 'OK' to proceed !

Fig. 7-2 Warning W11

1. Check that both non-PVC bags with physiological saline solution are hanging on IV-pole.
2. Check that reinfusion line is connected to the 1500 ml compartment of saline bag and seal of saline bag is broken.
3. Open clamps on reinfusion line.
4. Take buffer bag from load cell. Remove buffer line from buffer bag and connect buffer line to 1500 ml saline bag.
5. Open break seal of saline bag and open clamp on buffer line.
6. Close clamp on plasma line directly after plasma filter.
7. Turn over plasma filter, precipitate filter and heparin adsorber.
8. After performing all steps, press *OK* key to confirm.
9. Select *Start Plasma* menu item in menu bar and press *Enter* key to start plasma reinfusion.

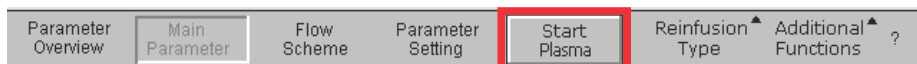

Fig. 7-3 *Start Plasma* item selected in the menu bar

CAUTION!

Risk to patient in case of an excessively fast plasma reinfusion!
Some patients experience flushing on the arm used for reinfusion and in the throat area, nausea and/or headaches.

- Blood flow should be at least 10 ml/min faster than reinfusion flow to ensure an imbalance between corpuscular parts and plasma parts during reinfusion.
- Otherwise: Reduce reinfusion flow to approx. 20 ml/min and increase blood flow as much as possible (approx. 80 ml/min), so that flow rates similar to those during therapy are achieved.

CAUTION!

Risk to patient in case of an excessively plasma/blood reinfusion step!
Excessively performed reinfusion can lead to an overload of saline solution to the patient.

- Comply with the recommended reinfusion volume.
- Exceed the reinfusion volume only if a filter has been changed during therapy.

NOTICE!

If the precipitate filter pressure rises during plasma reinfusion due to high filter saturation, the reinfusion flow should be reduced.

When the reinfusion volume is reached, all pumps except the blood pump stop. The blood flow is maintained. The default setting of the plasma reinfusion volume is 400 ml.

A *Warning* window is displayed indicating the next steps to be performed:

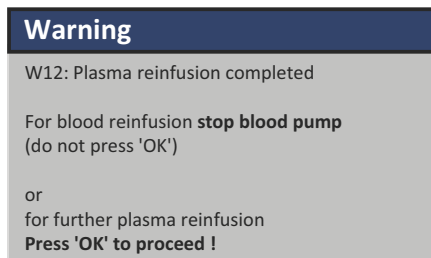

Fig. 7-4 Warning W12

7.2 Blood Reinfusion



As long as the blood pump is running, the menu item *Blood Reinfusion* is not active.



1. Press *Start/Stop* key to stop blood pump.

↳ The next steps are summarized in the *Warning* window that appears:

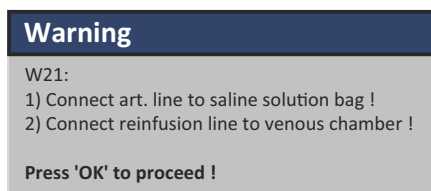

Fig. 7-5 Warning W21

2. Remove arterial line from patient's arterial access and connect the line to 500 ml saline bag on IV-pole.
3. Close clamp on reinfusion line.
4. Remove reinfusion line from saline bag and screw it to port of venous chamber.
5. Open clamps on reinfusion line and port.
6. Press *OK* key to confirm *Warning* window.
7. Press *Start/Stop* key to start blood pump.

↳ The default setting of the blood reinfusion volume is 300 ml.
When a blood reinfusion volume of 150 ml has been reached, the warning *W41: Open plasma clamp and close venous clamp !* appears in the Alarm/Note line of the screen.

8. Open clamp on plasma line after plasma filter.
9. Close clamp on venous line to venous chamber.

↳ The saline solution is now pumped through the membrane of the plasma filter to the plasma side of the filter. In this manner, the plasma from the plasma filter is also reinfused.

↳ The blood pump stops automatically when the set blood reinfusion volume is reached.
The message *W17: Blood reinfusion completed* appears in the Alarm/Note line of the screen.

10. After blood pump has stopped, remove venous line from patient's venous access.

For the patient, the treatment is now completed.

7.3 Terminating Treatment

1. Note down all necessary treatment data of patient.
2. Select *Additional Functions* menu item in menu bar and press *Enter* key.
 - ↳ The submenu *Additional Functions* opens.

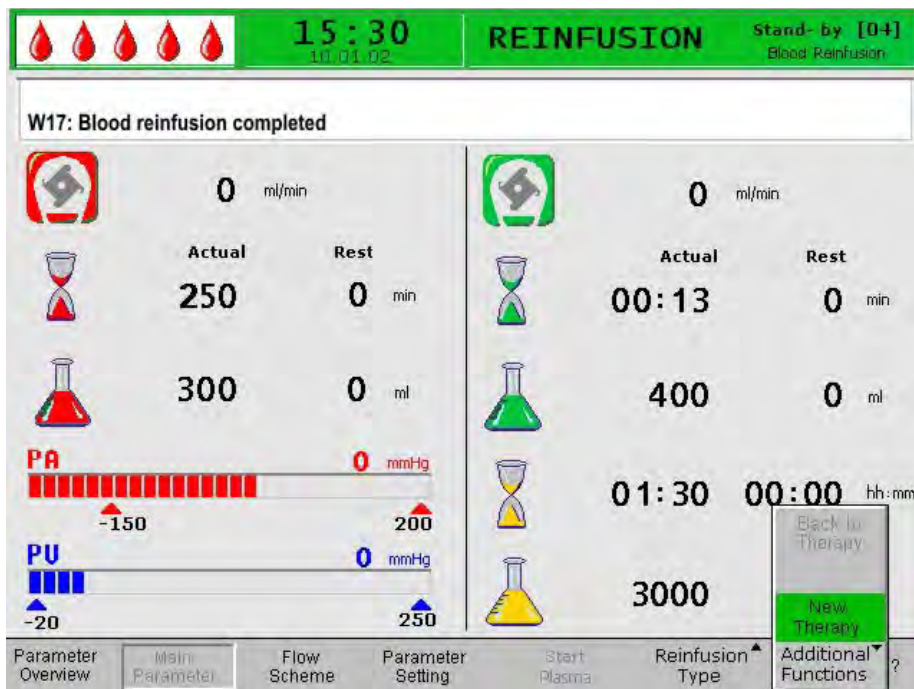

Fig. 7-6 *New Therapy* item in *Additional Functions* submenu

3. Select menu item *New Therapy* and press *Enter* key.
 - ↳ The *Warning* window appears with the warning *W36: Are you sure to start a new therapy ? Return to this therapy is not possible.*

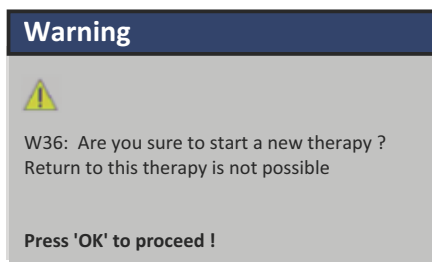

Fig. 7-7 Warning W36

4. Press *OK* key to confirm message.
 - ↳ The display returns to the start screen. Now the machine can be prepared for another treatment or switched off.

NOTICE!

All data of the currently performed therapy are deleted when you quit the reinfusion phase by pressing the OK key.

5. Remove all disposables from machine and dispose of accordingly.

7.4 Parameter Setting

7.4.1 Parameter Setting in the Main Parameter Screen

For detailed information about setting of parameters, see section 2.6 Parameter Setting (40)

After selecting the *Parameter Setting* item in the menu bar, all parameters which can be changed are displayed in red.

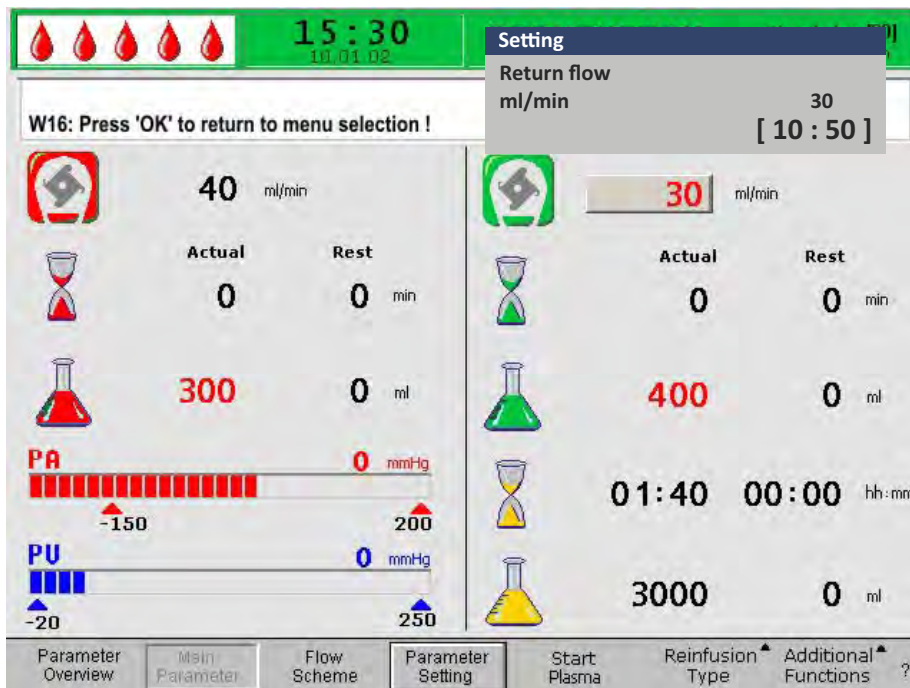





Fig. 7-8 Parameter selection in the *Main Parameter* screen

7

The following parameters can be set in the reinfusion phase:

Icon	Parameter	Default	Range	Step Size
	Return flow [ml/min]	30	10 – 50	5
	Plasma reinfusion volume [ml]	400	400 – 1000	50
	Blood reinfusion volume [ml]	300	100 – 600	50

The changing of the following parameters must be confirmed with the *OK* key since they are relevant to patient safety:

- Return flow (plasma reinfusion flow)
- Blood reinfusion volume

7.4.2 Parameter Setting in the Parameter Overview Screen

For detailed information about setting of parameters, see section 2.6 Parameter Setting (40)

After selecting the *Parameter Setting* item in the menu bar, all parameters which can be changed are displayed in red. For a better overview, blood flow (red) and reinfusion flow (green) are marked with colored arrows.



Fig. 7-9 Parameter selection in the *Parameter Overview* screen

The following parameters can be set in the reinfusion phase:

- Return flow [ml/min]
- Temperature [°C]
- PA MIN [mmHg]
- PA MAX [mmHg]
- PV MIN [mmHg]
- PV MAX [mmHg]
- PPL MIN [mmHg]
- TMP MAX [mmHg]
- PPF MIN [mmHg]
- PDF MIN [mmHg]
- PDF MAX [mmHg]
- PDPA MAX [mmHg]
- PPL Threshold [mmHg]
- Ratio Dialysate/Plasma

The changing of the following parameters must be confirmed with the *OK* key since they are relevant to patient safety:

- Return flow
- PA MIN
- PA MAX
- PV MIN
- PV MAX
- Ratio Dialysate/Plasma

Plasma and blood reinfusion volume can be set only in the *Main Parameter* screen.

For more details about parameter setting values, see section 5.2.2 Parameter Setting in the Parameter Overview Screen (82).

7.4.3 Parameter Setting in the Flow Scheme Screen

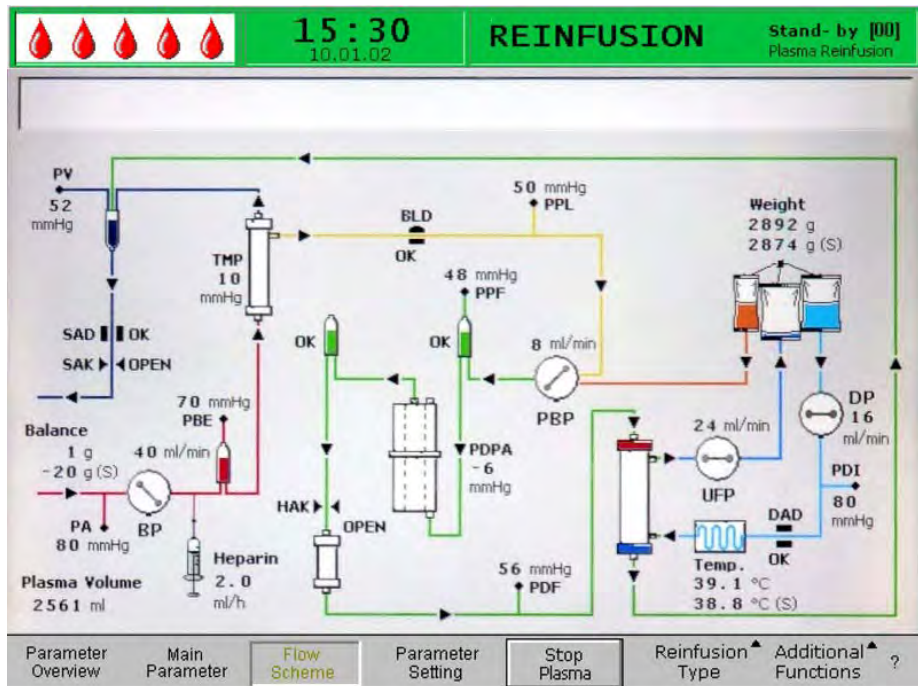

Fig. 7-10 Flow Scheme screen in the reinfusion phase

After selecting the *Parameter Setting* item in the menu bar, the screen changes to the setting screen of the *Parameter Overview*. Here, all settings can be performed as described in section 7.4.2 Parameter Setting in the Parameter Overview Screen (108).

7.5 Additional Functions

Terminating Plasma Reinfusion

The plasma reinfusion can be terminated prematurely at any time:



1. Select *Stop Plasma* menu item in menu bar and press *Enter* key.

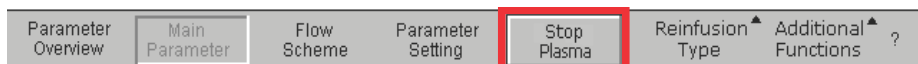

Fig. 7-11 Stop Plasma item in the menu bar



2. To move on to blood reinfusion, press *Start/Stop* key to stop blood pump.
↳ The blood pump stops.



3. Select *Reinfusion Type* menu item in menu bar and press *Enter* key.
↳ The *Reinfusion Type* submenu is opened.

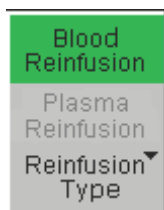

Fig. 7-12 Reinfusion Type submenu

- 4. Select *Blood Reinfusion* menu item in this submenu and press *Enter* key.
 - ↳ The *Warning* window appears with the warning *W21: 1) Connect art. line to saline solution bag ! 2) Connect reinfusion line to venous chamber !.*

i The submenu *Blood Reinfusion* is active only if the blood pump is stopped.

- 5. After connecting the lines accordingly, press *OK* key to start blood reinfusion (see section 7.2 Blood Reinfusion (105)).

Additional Functions

Under the *Additional Functions* menu item more functions are available:

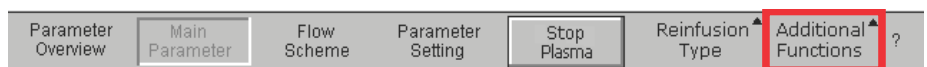

Fig. 7-13 *Additional Functions* item in the menu bar

7

The *Back to Therapy* menu item is active only during plasma reinfusion and allows return to therapy.



Fig. 7-14 *Back to Therapy* item in *Additional Functions* submenu

The *New Therapy* menu item is active only during blood reinfusion. It allows to completely terminate the treatment and return to the start screen (see section 6.2 End of Therapy (93)).



Fig. 7-15 *New Therapy* item in *Additional Functions* submenu

Table of contents

8 Disinfection 115

8 Disinfection

All parts coming into physical contact with the patient are disposables. Therefore, no internal disinfection is required after treatment.

Solutions for Surface Disinfection and External Cleaning

NOTICE!

Only use appropriate cleaning agents in accordance with the respective instructions for use to avoid damaging the machine!

Product	Concentration	Manufacturer
2-Propanol 70 % (V/V)	100 %	B. Braun
Hexaquart® plus	2 %	B. Braun
Incidin® Rapid	3 %	Ecolab Healthcare, Wien, Austria
Kodan® Tinktur Forte ^a	100 %	Schülke & Mayr GmbH, Norderstadt, Germany
Meliseptol® rapid	100 %	B. Braun
Melsitt®	3 %	B. Braun

a. colorless, skin disinfection

Monitor and Housing

WARNING!

Risk to patient due to cross-infection caused by contamination!

- It is recommended to clean the outer surface of the machine after each therapy by an appropriate disinfectant.
 - In case of surface contamination with blood, disinfect and clean properly.
 - In case of contamination of pressure connectors with blood, disinfect and clean properly.
-

CAUTION!

Risk of electric shock and machine damage if fluid enters the machine!

- Ensure that no fluid enters the machine.
 - Ensure that no fluid is on the mains plug or mains socket.
 - Do not wipe the surface too moistly. If necessary, dry with smooth cloth afterwards.
-

1. Open all pump covers and hinged sensor covers to ensure that all surfaces that can be reached are moistened with cleaning agents.
2. Clean housing parts and monitor with approved cleaning agents (see above).

Pump Rollers

1. Wipe pump rollers with disinfection spray but not too moistly. If necessary, dry with smooth cloth afterwards.

NOTICE!

Do not put pump rollers into a disinfectant bath to avoid damages and reduced efficacy!



If pump rollers have been removed for disinfection, the roller marked with a yellow point has to be re-installed in the plasma/buffer pump.

Table of contents

9	Troubleshooting	119
9.1	Self Tests	119
9.1.1	Hardware Self Tests and Corrective Actions	119
9.1.2	Self Test Duration and Alarm Codes	120
9.1.3	Dynamic Tests and Controls During Therapy and Reinfusion	127
9.2	Alarms and Remedial Action.....	128
9.2.1	Alarm Concept	128
9.2.2	List of all Alarms	130
9.3	Warnings and Remedial Action.....	144
9.3.1	Warning Concept	144
9.3.2	List of all Warnings	146
9.4	Problem Correction	153
9.4.1	Balance Reset	153
9.4.2	Deaeration of the Heparin Adsorber	155
9.4.3	Changing the Solution Bags	156
9.4.4	Changing the Plasma Filter	158
9.4.5	Changing the H.E.L.P. Precipitate Filter	159
9.4.6	Changing the H.E.L.P. Heparin Adsorber	160
9.4.7	Changing the H.E.L.P. Ultrafilter	161
9.4.8	Manual Blood Return	162
9.4.9	Remedying SAD Alarms	163

9 Troubleshooting

9.1 Self Tests

The machine performs various self tests during the start-up, priming and rinsing, therapy and reinfusion. Some of these tests are performed in periodic intervals to ensure the safety of the patient.

9.1.1 Hardware Self Tests and Corrective Actions

Numeric Test



During start-up, this test displays the numeric strings (0 1 2 3 4 5 6 7 8 9) in the three different fonts which the machine has available (see section 4.1 Switching On and Initial Tests (64)). The user has to check whether the sequence is correct.

If one of the self tests fails, a relevant warning is displayed. In this case, ensure that the machine is in the initial state. Then another self test can be performed after correction of the cause of the error by selecting the *RETEST* menu item in the menu bar and pressing the *Enter* key.

When the hardware tests and the numeric test have been successfully completed, the start screen is displayed after selecting the *END* menu item in the menu bar and pressing the *Enter* key.

LED Test

During the start-up self tests, the hardware performs self tests of the LEDs above the

- *Alarm* key 
- *OK* key 
- *Start/Stop* key 

by switching them on intermittently.

The user must check that all LEDs operate correctly.

T0 Tests

The T0 tests are performed continuously and periodically over the complete operating period of the machine.

Static T1 Tests

The static T1 tests are performed after the machine is switched on (self tests at start-up). The therapy can be started only after all tests have been performed without error.

Dynamic T1 Tests

Dynamic T1 tests are performed during the priming and rinsing phase to ensure the correct installation of the lines.

Self Tests During Priming and Rinsing

The machine performs various dynamic self tests during the priming and rinsing phase to ensure the functionality of the following units:

- Load cell
- Blood leak detector (BLD)
- Dialysate air detector (DAD)
- Safety air detector (SAD)
- Arterial pressure (PA)
- Plasmafilter pre-pressure (PBE) and venous pressure sensor (PV)
- Pumps
- Heating
- The temperatures of the dialysate measured by the controller and the supervisor, respectively, are compared

Self Tests During Therapy

Various self tests are performed during the entire therapy in periodic intervals for the safety of the patient. The following parameters are monitored:

- Fluid weight on the load cell
- Blood leak detector (BLD)
- Safety air detector (SAD)

Corrective Actions

Proceed as follows in the case of a failed test:



1. Press *Alarm* key to mute acoustic alarm.
2. Follow instructions on monitor and determine which test failed.
3. Correct displayed cause, if possible.
4. Press *Alarm* key again to repeat test.



9.1.2 Self Test Duration and Alarm Codes

T0 Tests	Time	Alarm Code
Tests by the Controller		
Proper Supervisor operation Periodical life signal is received from Supervisor.	3 s	A99
Identical functional states of controller and supervisor Verification whether the controller and the supervisor have the same working state.	5 s	A02
Identical arterial pressures of controller and supervisor The arterial pressures (PA) of the controller and the supervisor may deviate by a maximum of ± 30 mmHg (in priming and rinsing only).	30 s	A03

T0 Tests	Time	Alarm Code
<p>Identical venous pressures of controller and supervisor</p> <p>The venous pressures (PV) of the controller and the supervisor may deviate by a maximum of ± 30 mmHg (in priming and rinsing only).</p>	30 s	A04
<p>Identical weight values of controller and supervisor</p> <p>The weights on the load cell determined by the controller and the supervisor may deviate by a maximum of ± 250 g (in priming and rinsing only and if plasma side is running).</p>	30 s	A05
<p>Identical temperatures of controller and supervisor</p> <p>The temperatures determined by the controller and the supervisor may deviate by a maximum of 2.5 °C (in priming and rinsing only).</p>	180 s	A06
<p>BLD self test</p> <p>This test is performed every 5 minutes during the therapy and reinfusion phase.</p>	5 min	A07
<p>SAD self test</p> <p>The first test verifies whether the sensor detects an air signal. The second test compares the voltage threshold and the calibration value.</p> <p>This test is performed every 1.5 seconds (= time required by an air bubble at maximum blood flow to reach the venous cannula) during priming and rinsing as well as during the therapy and reinfusion phases.</p>	1.5 s	A08
<p>Load cell self test</p> <p>The load cell is tested every 3 seconds.</p>	3 s	A09
<p>Running internal communication</p> <p>Correct periodical communication is performed with the User Interface.</p>	4 s	A10
Tests by the Supervisor		
<p>SAD clock test</p> <p>Time control of the SAD is checked.</p>	0 s	A80
<p>SAD test</p> <p>No or too many SAD tests are executed by the Controller or fluid is detected during test.</p>	2 s	A90
<p>SAD reference test</p> <p>Reference voltage of SAD is tested to be within limit.</p>	1 s	A94
<p>Running internal communication</p> <p>Correct periodical communication is performed with the User Interface and periodical life signal from Controller is received.</p>	6 s 3 s	A99

Static T1 Tests	Alarm Code
Tests by the Controller	
ROM-RAM The ROMs and RAMs of the controller are verified using a CRC (cyclic redundancy check).	
Calibration data The calibration data of the controller are verified using a CRC.	
Sensor ZERO test The controller analyzes the following target values: <ul style="list-style-type: none"> • Arterial pressure (within ± 20 mmHg) • Prefilter pressure (within ± 20 mmHg) • Venous pressure (within ± 20 mmHg) • Weight (below 50 g) • SAD (in air detection) • PCLD (in air detection) • HCLD (in air detection) • DAD (in air detection) Verification of whether the dialysate air detector (DAD), the sensor for the level monitoring of the precipitate chamber (PCLD) and the sensor for the level monitoring of the heparin adsorber chamber (HCLD) detect an air signal.	A13 – A20
Supervisor 24 V relay The controller checks whether the supervisor can stop all pumps by means of the 24 V relay. <ul style="list-style-type: none"> • Controller activates the blood pump with a flow rate of 100 ml/min for 5 seconds. • The supervisor opens the 24 V relay. The test passes when the controller detects that the blood pump is stopped.	A21
Supervisor heating relay The controller checks whether the supervisor initiates the switching off of the heating via the heating relay. <ul style="list-style-type: none"> • The supervisor opens the heating relay. • The controller activates the heater to the maximum temperature for 20 seconds. The test passes when the temperature deviation is less than 1 °C.	A22

Static T1 Tests	Alarm Code
<p>Controller alarm tone buzzer</p> <p>The test includes the successive activation of all four alarm tones:</p> <ul style="list-style-type: none"> • Power failure (long alarm tone) The control system initiates the alarm situation of a mains failure for 2 seconds. • Controller alarm (continuous alarm tone) The control system initiates the buzzer for 2 seconds. • Supervisor alarm (continuous alarm tone) The supervisor system activates the buzzer for 2 seconds. • Warning (three alarm tones in successive short intervals) The monitor system activates the warning buzzer for 2 seconds. No danger exists for the patient. <p>The user is responsible for checking whether the buzzers function correctly.</p>	
Tests by the Supervisor	
<p>ROM-RAM</p> <p>The ROMs and RAMs of the supervisor are verified using a CRC (cyclic redundancy check).</p>	
<p>Calibration Data</p> <p>The calibration data of the supervisor are verified using a CRC.</p>	
<p>Sensor ZERO test</p> <p>The supervisor analyzes the following set values:</p> <ul style="list-style-type: none"> • Arterial pressure (within ± 20 mmHg) • Venous pressure (within ± 20 mmHg) • Weight (below 100 g) • SAD (in air detection) 	<p>A95 – A98</p>
<p>Heparin pump test</p> <p>The supervisor initiates a heparin bolus and checks the uniform delivery rate of the pump by means of a light barrier.</p> <p>The piston guide should be engaged in the middle position!</p>	<p>A93</p>
<p>Supervisor alarm tone buzzer</p> <p>The test includes the activation of the alarm tone:</p> <ul style="list-style-type: none"> • Supervisor alarm buzzer (continuous alarm tone) The supervisor system activates the buzzer for 2 seconds. <p>The user is responsible for checking whether the buzzer functions correctly.</p>	

The following dynamic tests are performed by the controller in the priming and rinsing phase. In the table below, the step number indicates during which step of the automatic blood side filling (section 5.1 Automatic Priming and Rinsing (77)) the tests are performed.

Dynamic T1 Tests	Step	Alarm Code
<p>PPF transducer connection test</p> <p>While the precipitate filter is filled the correct position of the PPF transducer is tested.</p> <p>The connection is correct if the controller recognizes a pressure deviation (more than ± 3 mmHg) as long as the plasma/buffer pump is running.</p>	4	A74
<p>Weight deviation by the plasma/buffer pump</p> <p>Verification whether the weight decrease on the load cell corresponds to the delivery rate of the plasma/buffer pump (65 ml/min).</p> <p>The test starts after activation of step 4 of the priming and rinsing phase as soon as 10 g have been delivered. For a duration of 30 s, the weight decrease must be higher than 20 g and less than 40 g, otherwise an alarm will be initiated and the test sequence has to be repeated.</p> <p>Priming cannot be completed if there is a fluid level in the precipitate chamber.</p>	4	A26
<p>HAK leakage test</p> <p>Verification whether the HAK can be closed and the connection line is inserted properly into HAK. Therefore the Controller checks during priming phase of the precipitate filter if the PPF remains below 350 mmHg after 1000 ml filling volume have been reached and HAK is closed.</p> <p>After filling the precipitate filter (step 4) and reaching the fluid level in the precipitate chamber and heparin adsorber chamber, there must be a pressure of > 350 mmHg on the PPF when HAK is closed. At the same time PDPA is to be > 250 mmHg. If the PDPA is < 250 mmHg, an alarm will be initiated. Acknowledge the alarm. The test will only be repeated twice.</p>	4	A33
<p>Blood leak detector (BLD) test</p> <p>The blood leak detector is tested for its general functionality and self calibration.</p> <ul style="list-style-type: none"> • Self calibration failed • Functionality test failed <p>If the reason for the alarm cannot be fixed, therapy cannot be started.</p>	5	A35 A07

Dynamic T1 Tests	Step	Alarm Code
<p>Deaeration of heparin adsorber and ultrafilter (no test)</p> <p>As soon as there is fluid in the heparin adsorber chamber a short level adjustment is performed in the precipitate and heparin adsorber chamber. Afterwards the heparin adsorber is primed until a volume of 225 ml is reached. Filtrate line and ultrafilter are deaerated.</p> <p>During priming of the heparin adsorber, the levels cannot be set manually. In this phase, balance and level adjustment alarms are suppressed.</p>	6 – 8	
<p>Deaeration of the dialysis side and dialysis side tests</p> <p>During this phase, the dialysis side is tested. The DAD is deaerated and the plate warmer is tested. Afterwards dialysate pump and ultrafiltration pump are tested. The line system is checked for correctness at the end.</p> <p><i>Deaeration of the dialysis side</i></p> <p>Blood pump starts running with 11 ml/min in order to deaerate and prime the dialysis fluid line.</p> <p><i>Plate warmer test</i></p> <p>During this priming phase, the plate warmer is tested. Within 2 minutes, a temperature of > 41.5 °C at the Controller and > 42 °C at the Supervisor must be measured.</p> <p><i>DAD test</i></p> <p>The dialysate pump increases its speed to 200 ml/min. During this phase, the DAD is tested. It must detect fluid within 20 seconds.</p> <p><i>Dialysis test</i></p> <ul style="list-style-type: none"> • During dialysis tests, dialysate pump (DP) and ultrafiltration pump (UFP) run with 140 ml/min. • The values must be reached within 160 seconds. • The function of DP is tested before UFP, in order to get a positive PDI and to avoid collapsing of plate warmer bag. • The UFP test checks if PDI remains stable at approx. 120 mmHg. DP flow and UFP flow should have a ratio of $UFP = 0.9 DP$. Regulation limits are: <ul style="list-style-type: none"> – $PDI > PDI_{Basis} + 20 \text{ mmHg}$ (= 140 mmHg), then $UFP = 0.9 DP + 20 \text{ ml/min}$ – $PDI > PDI_{Basis} - 20 \text{ mmHg}$ (= 100 mmHg), then $UFP = 0.9 DP - 20 \text{ ml/min}$ 	9	<p>A32 A28 A27 A29 A30 A31</p> <p>A32</p> <p>A28</p> <p>A27</p>

Dynamic T1 Tests	Step	Alarm Code
<p>The alarm will be initiated in following situations:</p> <ul style="list-style-type: none"> • PDI > 200 mmHg at beginning of the test, UFP is standing still • PDI is not increased by 30 mmHg within 12 seconds while DP is running • PDI is not decreased by 30 mmHg within 12 seconds while UFP is running • PDI > 250 mmHg while ultrafiltration side is filled (UFP is standing still) • UF side cannot be filled within 160 seconds. This can be measured by a weight change at the load cell (comparison of weight before and after priming). <p><i>Leakage test of the line system</i></p> <p>The line system is tested for correct seat and leakage (leakage, leaky sensors, line ruptures) by the pressure test. The SAK is closed and all pumps are running.</p> <ul style="list-style-type: none"> • Pressure test: within 50 seconds > 200 mmHg must be reached at PV, PDF and PDI. • Leakage test: pressure decrease PV > 30 mmHg • Sensor test: <ul style="list-style-type: none"> – High pressure: PBE > 240 mmHg, PPL/PPF > 250 mmHg – Sensor leaky if: PBE–PV > 30 mmHg, PDF–PV > 30 mmHg, PDI–PV > 40 mmHg, PPL < 150 mmHg, PPF < 150 mmHg. • Rupture test of pump segments: Rotation of pumps with following speeds <ul style="list-style-type: none"> – BP 10 ml/min., PBP 2 ml/min, DP 10 ml/min, UFP 10 ml/min with subsequent sensor test (see point 3) 		<p>A29</p> <p>A30</p> <p>A31</p> <p>A30</p>

9.1.3 Dynamic Tests and Controls During Therapy and Reinfusion

Blood Leak Detector

A blood leak alarm may occur if blood or air bubbles are in the plasma line. The reason can also be a failure in the BLD self test. The blood leak detector is not automatically calibrated after acknowledging an alarm. After A36 advice W38 appears.

- If the advice is confirmed by pressing the *OK* key, the blood leak detector is recalibrated. The sensor starts a new measurement.
- If the alarm is confirmed by pressing the *Alarm* key, it remains suppressed for one minute. Afterwards the sensor starts a new measurement.
- If the alarm is confirmed three times within short time by pressing the *Alarm* key, the warning W19 appears. If W19 is not confirmed, the alarm will be repeated. If W19 is confirmed by pressing the *OK* key (bridging the BLD function), the warning W20 will follow.
After having bridged the BLD function, contact technical service!

WARNING!

Risk to patient due to malfunction of the blood leak detector!
Multiple recalibrations during existing blood leak (red colored plasma) can lead to malfunction of the blood leak detector and therefore to uncontrolled infusion of free hemoglobin into the patient.

- Only recalibrate when you are sure that the alarm is caused by a failure of the blood leak detector (defect BLD or air bubble in plasma line) or when you are sure that coloring of the plasma is caused by a failure other than a membrane rupture of the plasma filter.
- Visually inspect the quality of the plasma separation.

WARNING!

Risk to patient when bridging the blood leak detection!

- Make sure that the plasma line is inserted properly into the BLD, otherwise the BLD is not able to detect any blood leakage.
- Only bridge the blood leak detection if you are sure that a malfunction of the blood leak detector caused the series of blood leak alarms.
- After bridging the blood leak detection, the therapy must constantly be controlled visually by the user for hemolysis or membrane rupture of the plasma filter.

Connection Test in Therapy and Reinfusion

The connection of the BicEL bags is tested.

Directly after start of therapy, the connection of the buffer line to the acetate buffer bag is tested. If there is no connection to the acetate buffer bag, an alarm appears on the screen.

Directly after start of Reinfusion, the connection of the reinfusion line to the reinfusion solution is tested. If there is no connection to the reinfusion solution, an alarm appears on the screen.

Control of Ultrafiltration

The ultrafiltration is controlled via PDF.

The upper limit of the balance error is reached when the corrective factor exceeds 23 %. Balance alarms will follow.

9.2 Alarms and Remedial Action

9.2.1 Alarm Concept

An alarm situation always requires special attention and immediate processing by the user. Alarms are displayed in the Alarm/Note line (Fig. 9-1, ①) and accompanied by an acoustic alarm tone.

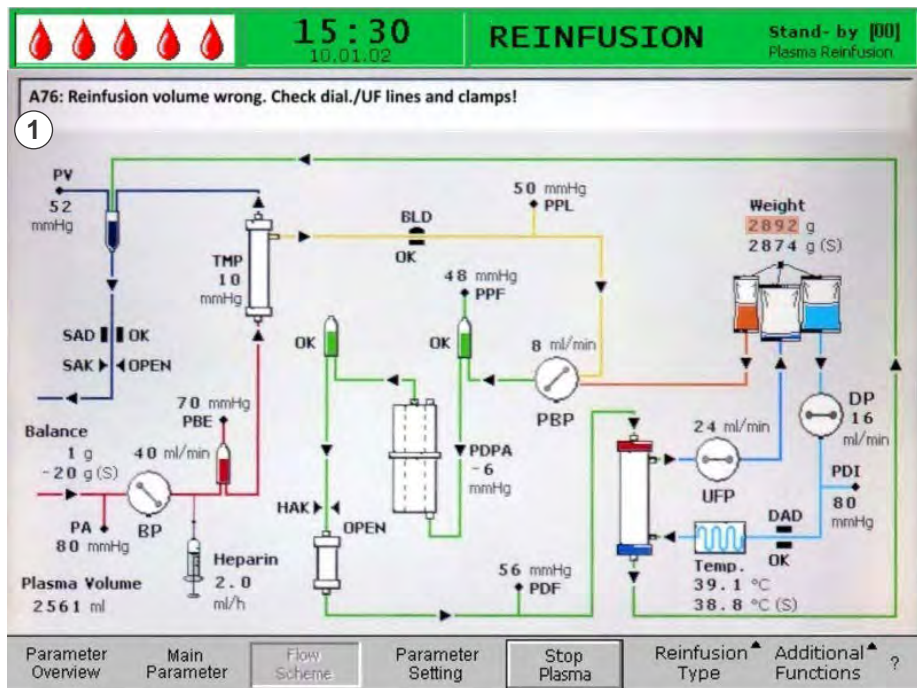

Fig. 9-1 Alarm indication in Alarm/Note line

When an alarm occurs, the screen display automatically changes to the flow scheme showing the position (e.g. blinking number for pressure alarms) affected by the alarm. After correction of the alarm, the display automatically changes back to the initial screen. If the same alarm occurs again within 30 seconds, the initial screen display is maintained.

Additionally, an active alarm is indicated by the red LEDs lighting above the *Alarm* key (Fig. 9-2, ①).

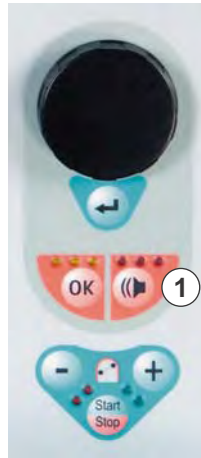

Fig. 9-2 *Alarm* key with red LEDs

An alarm is usually corrected in three steps:

1. Press *Alarm* key once to mute alarm tone.
2. Eliminate cause of alarm.
3. Press *Alarm* key again to acknowledge alarm.



Alarms which are caused by open pump covers (A59, A60, A61, A62), are self-regulating alarms. These alarms are corrected by closing the respective pump cover.

9.2.2 List of all Alarms

NOTICE!

Inform technical service if an alarm cannot be corrected with the measures described, if it occurs frequently and you cannot determine its cause or if a machine defect exists.

Code	Alarm Text	Alarm Cause	Corrective Action
A01	Supervisor system not working properly	Hardware problem	<ul style="list-style-type: none"> Acknowledge the alarm (twice). If the alarm is repeated switch machine off and on again to eliminate a possible transient failure. If the problem cannot be solved, close treatment immediately and inform technical service.
A02	Deviation between controller and supervisor state	Hardware problem	<ul style="list-style-type: none"> Acknowledge the alarm (twice). If it is not possible switch machine off and on again. If the problem cannot be solved, restart machine completely or close treatment immediately. If the problem cannot be solved with a machine restart inform technical service.
A03	Deviation of arterial pressure between controller and supervisor	Calibration or hardware problems	<ul style="list-style-type: none"> Acknowledge the alarm (twice). If the problem cannot be solved, inform technical service.
A04	Deviation of venous pressure between controller and supervisor	Calibration or hardware problems	<ul style="list-style-type: none"> Acknowledge the alarm (twice). If the problem cannot be solved, inform technical service.
A05	Deviation of weight fluid between controller and supervisor	Calibration or hardware problems	<ul style="list-style-type: none"> Acknowledge the alarm (twice). If the problem cannot be solved, inform technical service.
A06	Deviation of temperature between controller and supervisor	Calibration or hardware problems	<ul style="list-style-type: none"> Acknowledge the alarm (twice). If the problem cannot be solved, inform technical service.

Code	Alarm Text	Alarm Cause	Corrective Action
A07	Blood leak detector (BLD) test failed	Hardware problem	<ul style="list-style-type: none"> Acknowledge the alarm (twice). If the alarm is repeated switch machine off and on again. If the problem cannot be solved, stop treatment as soon as possible while visually inspecting for a possible blood leak in the plasma line. Inform technical service.
A08	Safety air detector (SAD) test failed	Hardware problem	<ul style="list-style-type: none"> Acknowledge the alarm (twice). If the alarm is repeated switch machine off and on again. If the problem cannot be solved, stop treatment immediately. Visually inspect for air bubbles in the venous return line. Inform technical service.
A09	Weight system test failed	Hardware problem	<ul style="list-style-type: none"> Acknowledge the alarm (twice). If the alarm is repeated switch machine off and on again. If the problem cannot be solved, stop therapy immediately. Then close treatment with reinfusion. Inform technical service.
A10	User interface not communicating	Hardware problem	<ul style="list-style-type: none"> Acknowledge the alarm (twice). If the alarm is repeated switch machine off and on again to eliminate a possible transient failure. If the problem cannot be solved, stop treatment immediately and inform technical service.
A13	Arterial pressure (PA) not zero	Consumables already or still mounted	<ul style="list-style-type: none"> Remove all consumables from the machine.
A14	Prefilter pressure (PBE) not zero	Consumables already or still mounted	<ul style="list-style-type: none"> Remove all consumables from the machine.
A15	Venous pressure (PV) not zero	Consumables already or still mounted	<ul style="list-style-type: none"> Remove all consumables from the machine.
A16	Load cell not empty or load cell error	Consumables already or still mounted	<ul style="list-style-type: none"> Remove all consumables from the machine.
A17	Line in SAD not empty or SAD error	Consumables already or still mounted	<ul style="list-style-type: none"> Remove all consumables from the machine.
A18	Precipitate chamber not empty or level sensor error	Consumables already or still mounted	<ul style="list-style-type: none"> Remove all consumables from the machine.

Code	Alarm Text	Alarm Cause	Corrective Action
A19	Heparin adsorber chamber not empty or level sensor error	Consumables already or still mounted	<ul style="list-style-type: none"> Remove all consumables from the machine.
A20	Line in DAD not empty or DAD error	Consumables already or still mounted	<ul style="list-style-type: none"> Remove all consumables from the machine.
A21	Power relay test failed	Defective hardware	<ul style="list-style-type: none"> Switch machine off and on again to restart machine.
A22	Heater relay test failed	Defective hardware	<ul style="list-style-type: none"> Switch machine off and on again to restart machine.
A26	Weight test error. Check bag, clamp, connection and pump !	<p>It was determined with weight test that</p> <ol style="list-style-type: none"> the plasma/buffer pump does not deliver correctly and there is a fluid level in the precipitate chamber <p>Reasons:</p> <ul style="list-style-type: none"> Malfunction of the plasma/buffer pump Malfunction of the load cell Error in refilling 	<ul style="list-style-type: none"> Ensure for 1. that: <ul style="list-style-type: none"> seal on saline bag is open. clamp on buffer line is open. buffer line is not kinked or clamped. plasma/buffer pump segments are not inserted crosswise and are in correct direction. Ensure for 2. that: <ul style="list-style-type: none"> there is no fluid in precipitate chamber and that sensors are fluid free. After eliminating the cause of the alarm and acknowledging the alarm, the test is automatically repeated.
A27	Dial. side test failed. Check DP/UF pumps and clamps on bags !	<p>It was determined with the dialysis test that the dialysate pump or the ultrafiltration pump does not deliver correctly</p> <p>Reason:</p> <ul style="list-style-type: none"> Dalysis fluid or ultrafiltration flow obstructed 	<ul style="list-style-type: none"> Ensure that: <ul style="list-style-type: none"> seals of dialysis fluid bags are open. clamps on dialysis fluid/ ultrafiltration lines are open. dialysis fluid/ultrafiltration line is not kinked or clamped. bags are hanging motionless on load cell. After eliminating the cause of the alarm and acknowledging the alarm, the test is automatically repeated.

Code	Alarm Text	Alarm Cause	Corrective Action
A28	DAD test failed	An error occurred during the DAD check Reason: <ul style="list-style-type: none"> Malfunction of DAD 	<ul style="list-style-type: none"> Ensure that: <ul style="list-style-type: none"> dialysis fluid line is inserted in dialysate air detector (DAD). clamps on dialysis fluid line are open. seals of dialysis fluid bags are open. connections between dialysis fluid bags and dialysis fluid line are firmly seated. After eliminating the cause of the alarm and acknowledging the alarm, the test is automatically repeated.
A29	Pressurization failed. PV, PDF, PDI < 200 mmHg. Check line in SAK !	Pressure build-up and pressure holding test failed	<ul style="list-style-type: none"> Ensure that: <ul style="list-style-type: none"> PBE pressure transducer is screwed on correctly. venous line is inserted in the tubing clamp (SAK). all lines are installed according to instruction. venous pressure transducer (PV) is correctly screwed on.
A30	Leakage test failed. Check connections of filters and sensors !	An error occurred during the check of the tubing clamp (SAK) and the line leakage test	<ul style="list-style-type: none"> Ensure that: <ul style="list-style-type: none"> venous line is inserted in tubing clamp (SAK). connections between lines and filters are firmly seated. venous pressure transducer (PV) is correctly screwed on. After eliminating the cause of the alarm and acknowledging the alarm, the test is automatically repeated.
A31	Pressure sensors failed. Check proper connection of sensors !	An error occurred during the calibration of the venous pressure (PV) and the inlet pressure on the plasma filter (PBE)	<ul style="list-style-type: none"> Ensure that: <ul style="list-style-type: none"> pressure transducer for PV is correctly screwed on. pressure transducer for PBE is correctly screwed on. After eliminating the cause of the alarm and acknowledging the alarm, the test is automatically repeated.
A32	Heater test failed	Malfunction of heater	<ul style="list-style-type: none"> Inform technical service.
A33	HAK test failed. Check line insertion !	Line not correctly inserted in HAK	<ul style="list-style-type: none"> Ensure that the filtrate line is inserted correctly in the HAK.

Code	Alarm Text	Alarm Cause	Corrective Action
A34	2 ml air infused	SAD has detected a total of > 2 ml air	<ul style="list-style-type: none"> • Ensure that: <ul style="list-style-type: none"> – lines have no leaks. When leaks are found, replace respective line. – all components have been connected firmly and properly. – venous chamber is sufficiently filled. If required, fill venous chamber manually.
A35	Blood leak detector (BLD) calibration failed	Malfunction of blood leak detector	<ul style="list-style-type: none"> • Inform technical service.
A36	Blood leakage detected	BLD detects a blood leak or larger air bubbles in the line	<ul style="list-style-type: none"> • Visually inspect the line after plasma filter. Replace the plasma filter when a blood leak is found (see section 9.4.4 Changing the Plasma Filter (158)). • If air bubbles are found, check connections for firm seating and lines for possible damage.
A37	Air in venous line. Set PV to -50 mmHg to remove the air !	Air found in venous line	<ul style="list-style-type: none"> • Clamp the venous line with the clamp between plasma filter (venous outlet) and venous chamber. • Set a clamp on the reinfusion line at connection to venous chamber. • Set level at PV to -50 mmHg (level adjustment will be stopped at -100 mmHg). Observe that the pressure transducer PV is not filled up to the protector. • The tubing clamp (SAK) opens automatically and air is removed from venous line into venous chamber. • Using the level adjustment keys, manually adjust the level in the venous chamber again (PV > 0 mmHg). • Open the clamp on venous line. • Open the clamp on reinfusion line. • Acknowledge the alarm and continue treatment.
A38	Minimum arterial pressure (PA min)	Arterial pressure too low	<ul style="list-style-type: none"> • Ensure that the arterial access is free and properly connected. • If necessary, reduce blood flow.

Code	Alarm Text	Alarm Cause	Corrective Action
A39	Maximum arterial pressure (PA max)	Arterial pressure too high	<ul style="list-style-type: none"> • Ensure that the arterial access is free and properly connected. • If necessary, increase blood flow.
A40	Minimum prefilter pressure (PBE min)	Prefilter pressure too low	<ul style="list-style-type: none"> • Ensure that the venous access is free and properly connected.
A41	Maximum prefilter pressure (PBE max)	Prefilter pressure too high	<ul style="list-style-type: none"> • Ensure that: <ul style="list-style-type: none"> – venous access is free and properly connected. – venous line is not kinked or clamped.
A42	Minimum venous pressure (PV min)	Venous pressure too low	<ul style="list-style-type: none"> • Ensure that: <ul style="list-style-type: none"> – arterial access is free and properly connected. – buffer line is not kinked or clamped.
A43	Maximum venous pressure (PV max)	Venous pressure too high	<ul style="list-style-type: none"> • Ensure that: <ul style="list-style-type: none"> – venous access is free and properly connected. – venous line is not kinked or clamped.
A44	Minimum plasma pressure (PPL min)	Plasma pressure too low, plasma flow too high	<ul style="list-style-type: none"> • Ensure that: <ul style="list-style-type: none"> – blood flow/plasma flow ratio is approximately 3:1. – plasma filter is unobstructed and functional. Replace plasma filter if it is obstructed (see section 9.4.4 Changing the Plasma Filter (158)). • If necessary, reduce plasma flow.
A45	Maximum plasma pressure (PPL max)	Plasma pressure too high Defective PPL pressure transducer Defective pressure sensor	<ul style="list-style-type: none"> • Check the plasma line and replace it if defective.
A46	Low PPF. Check high chamber level, protector or buffer bag empty!	Precipitate filter pressure too low	<ul style="list-style-type: none"> • Ensure that: <ul style="list-style-type: none"> – clamp on buffer line is open. – seal of acetate buffer bag is open. – acetate buffer bag is not empty. – level in PPF chamber is not high and especially PPF protector is not wet.

Code	Alarm Text	Alarm Cause	Corrective Action
A47	Maximum precipitate filter pressure (PPF max)	Precipitate filter pressure too high Defective level detector	<ul style="list-style-type: none"> • Ensure that: <ul style="list-style-type: none"> – lines after precipitate chamber are not kinked or clamped. – pump segment is correctly inserted in ultrafiltration pump. – precipitate filter is not saturated. If precipitate filter is saturated, a rise of PDPA occurs in parallel. Replace filter in this case. – heparin adsorber is permeable. If this is not the case, replace heparin adsorber. – dialyzer is permeable. If this is not the case, replace dialyzer. • If necessary, reduce plasma flow or reinfusion flow.
A48	Minimum dialysis filter pressure (PDF min)	Dialyzer pressure too low (< -50 mmHg) Plasma flow too low	<ul style="list-style-type: none"> • Ensure that there is no dialyzer leakage. If there is a leakage, replace the dialyzer. • If necessary, increase plasma flow.
A49	Maximum dialysis filter pressure (PDF max)	Dialyzer pressure too high	<ul style="list-style-type: none"> • Ensure that: <ul style="list-style-type: none"> – lines after dialyzer are not kinked or clamped. – pump segment is correctly inserted in ultrafiltration pump. – dialysate drain line is not kinked or clamped. – clamps on dialysate drain are open.
A50	Minimum dialysate inlet pressure (PDI min)	Inlet pressure of dialysis fluid too low Defective dialysate pump	<ul style="list-style-type: none"> • Ensure that: <ul style="list-style-type: none"> – clamps on dialysis fluid line are open. – seals of dialysis fluid bags are open.
A51	Maximum dialysate inlet pressure (PDI max)	Inlet pressure of dialysis fluid too high	<ul style="list-style-type: none"> • Ensure that: <ul style="list-style-type: none"> – warming bag is inserted correctly and without kinks. – line between dialyzer and plate warmer is not kinked or clamped.

Code	Alarm Text	Alarm Cause	Corrective Action
A53	Maximum transmembrane pressure (TMP max)	Transmembrane pressure too high Defective pressure sensors for PV, PPL or PBE	<ul style="list-style-type: none"> • Ensure that: <ul style="list-style-type: none"> – venous pressure (PV) is not too high. – plasma prefilter pressure (PBE) is not too high. – plasma filter is not clogged. Replace filter if it is clogged (see section 9.4.4 Changing the Plasma Filter (158)). – blood flow/plasma flow ratio is approximately 3:1. – pressure transducers for PV, PPL and PPE are correctly seated and are dry. • If necessary, reduce blood flow. • If necessary, reduce plasma flow.
A54	Maximum pressure drop precipitate filter/ adsorber (PDPA max)	Pressure drop between precipitate filter and adsorber too high	<ul style="list-style-type: none"> • Ensure that: <ul style="list-style-type: none"> – precipitate filter is not saturated. Replace filter if it is saturated (see section 9.4.5 Changing the H.E.L.P. Precipitate Filter (159)). – lines between precipitate filter and adsorber are not kinked or clamped.
A55	Low prec.chamber level. Check air bubbles in chamber and locking!	Precipitate chamber level sensor detects too low fluid level	<ul style="list-style-type: none"> • Ensure that: <ul style="list-style-type: none"> – buffer line is not kinked or clamped. – seal of acetate buffer bag is open. – acetate buffer bag is not empty. – precipitate chamber is positioned and level sensor is locked properly. – no air bubble is attached to inner chamber wall.
A56	Fluid level in heparin adsorber chamber too low	HCLD detects air Defect of automatic level adjustment	<ul style="list-style-type: none"> • Check that the precipitate filter is not saturated. Replace the filter if it is saturated (see section 9.4.5 Changing the H.E.L.P. Precipitate Filter (159)).

Code	Alarm Text	Alarm Cause	Corrective Action
A57	Air in dialysate line	DAD detects air	<ul style="list-style-type: none"> • Ensure that: <ul style="list-style-type: none"> – dialysate bags are full. – clamps on dialysate lines are open. – seals of dialysate bags are open. – dialysate line is not damaged and connections to bags are tight. Replace line if it is damaged.
A58	Stop of blood pump too long. Clotting danger !	Blood pump stop > 120 seconds	<ul style="list-style-type: none"> • Start the blood pump to eliminate the alarm and to acknowledge the error.
A59	Blood pump cover open	Blood pump cover open Magnetic sensor of pump defective	<ul style="list-style-type: none"> • Close pump cover. • Inform technical service.
A60	Plasma/buffer pump cover open	Plasma/buffer pump cover open Magnetic sensor of pump defective	<ul style="list-style-type: none"> • Close pump cover. • Inform technical service.
A61	UF pump cover open	Ultrafiltration pump cover open Magnetic sensor of pump defective	<ul style="list-style-type: none"> • Close pump cover. • Inform technical service.
A62	Dialysate pump cover open	Dialysate pump cover open Magnetic sensor of pump defective	<ul style="list-style-type: none"> • Close pump cover. • Inform technical service.
A63	Blood pump speed error	Wrong speed of blood pump Pump defective	<ul style="list-style-type: none"> • Ensure that the pump segment is correctly inserted in the blood pump. • Inform technical service.
A64	Plasma/buffer pump speed error	Wrong speed of plasma/buffer pump Pump defective	<ul style="list-style-type: none"> • Ensure that the pump segments are correctly inserted in the plasma/buffer pump. • Inform technical service.
A65	UF pump speed error	Wrong speed of ultrafiltration pump Pump defective	<ul style="list-style-type: none"> • Ensure that the pump segment is correctly inserted in the ultrafiltration pump. • Inform technical service.
A66	Dialysate pump speed error	Wrong speed of dialysate pump Pump defective	<ul style="list-style-type: none"> • Ensure that the pump segment is correctly inserted in the dialysate pump. • Inform technical service.

Code	Alarm Text	Alarm Cause	Corrective Action
A67	Maximum dialysate temperature	Dialysis fluid too warm (> 41.5 °C for > 10 s) Defective heating element	<ul style="list-style-type: none"> • Close the cover of the plate warmer. • Inform technical service.
A68	Excessive weight change. Check bags and lines !	Weight variation between 50 and 200 g for more than 5 s or weight variation > 200 g	<ul style="list-style-type: none"> • Ensure that: <ul style="list-style-type: none"> – bags are hanging motionless on load cell. – lines are hanging free and do not pull on bags on load cell. – bags do not move too much. • This alarm is also activated if a bag has been removed from or added to the load cell. In this case correct the error.
A69	Balance error	Balance error > 200 g Defect of plasma/buffer pump, of ultrafiltration pump or of load cell	<ul style="list-style-type: none"> • Ensure that: <ul style="list-style-type: none"> – seals of saline bags and dialysis fluid bags are open. – lines are not kinked or clamped. – clamps on buffer line and on dialysis fluid line are open. – dialysis fluid line is inserted into support on load cell. – pump segments are correctly inserted.
A70	Weight too high or load cell empty	Weight above 24500 g or below 50 g	<ul style="list-style-type: none"> • Reduce the weight on load cell. • Hang the bags back on to the load cell.
A72	Acet. buffer bag connection error. Open clamps on bag!	Machine detects too low delivery rate of the plasma buffer pump due to too low PPF	<ul style="list-style-type: none"> • Check for correct connection between acetate bag and buffer line. Ensure that the seals and clamps are open and check that the buffer line is free and not kinked.
A73	High precipitate chamber level	Precipitate chamber level is too high, PPF protector is wet. No PPF pressure increase in case of closed HAK.	<ul style="list-style-type: none"> • Ensure that: <ul style="list-style-type: none"> – Precipitate chamber level is not too high and PPF protector is not wet. – PPF protector is connected properly. – precipitate chamber is positioned and level sensor is locked properly. – no air bubble is attached to inner chamber wall.

Code	Alarm Text	Alarm Cause	Corrective Action
A74	PPF protector is not connected	No pressure change on PPF	<ul style="list-style-type: none"> • Ensure that the PPF protector is connected properly.
A75	Solution connection problem. Check lines, clamps and bags!	After changing from the priming and rinsing to the therapy phase or from the therapy to the reinfusion phase, the load cell does not detect weight reduction	<ul style="list-style-type: none"> • Ensure that: <ul style="list-style-type: none"> – seals of saline bags/acetate buffer bag are open. – clamps on saline lines/ acetate buffer line are open. – saline/acetate buffer lines are not kinked or clamped. – bags are hanging motionless on load cell.
A76	Reinfusion volume wrong. Check dial./UF lines and clamps!	Balance error in plasma reinfusion phase	<ul style="list-style-type: none"> • Ensure that: <ul style="list-style-type: none"> – pump segments (DP and UFP) are inserted properly. – lines are not kinked. – clamps connecting dialysis fluid and ultrafiltration line with drainage bags are open.
A77	Reinfusion connection error. Open both clamps on IV pole bag!	Pressure test at beginning of reinfusion failed	<ul style="list-style-type: none"> • Ensure that the plasma reinfusion line is connected to the upper rinsing bag. • Check that the clamps and seals are open and that the plasma reinfusion line is not kinked.

NOTICE!

Alarms marked with (S) are generated by the supervisor. If these alarms are active, it is possible that the controller does not operate correctly. Inform technical service if an alarm cannot be corrected with the actions suggested below or if it occurs frequently.

Code	Alarm Text	Alarm Cause	Corrective Action
A80	(S) SAD clock error. Switch off and on !	SAD status between controller and supervisor could not be synchronized	<ul style="list-style-type: none"> • Switch machine off and on again
A81	(S) Blood pump speed error	Wrong speed of blood pump Pump defective	<ul style="list-style-type: none"> • Ensure that the pump segment is correctly inserted in the blood pump. • Inform technical service.

Code	Alarm Text	Alarm Cause	Corrective Action
A82	(S) Plasma/buffer pump speed error	Wrong speed of plasma/ buffer pump Pump defective	<ul style="list-style-type: none"> • Ensure that the pump segment is correctly inserted in the plasma/ buffer pump. • Inform technical service.
A83	(S) UF pump speed error	Wrong speed of ultrafiltration pump Pump defective	<ul style="list-style-type: none"> • Ensure that the pump segment is correctly inserted in the ultrafiltration pump. • Inform technical service.
A84	(S) Dialysate pump speed error	Wrong speed of dialysate pump Pump defective	<ul style="list-style-type: none"> • Ensure that the pump segment is correctly inserted in the dialysate pump. • Inform technical service.
A85	Heparin pump problem. Check pump or syringe !	Syringe empty or current position of heparin pump wrong	<ul style="list-style-type: none"> • Ensure that: <ul style="list-style-type: none"> – syringe is not empty. – lock on heparin pump support is closed. – guide of heparin pump is no longer in maximum upper position.
A86	(S) Blood pump stop for too long	Blood pump stop > 150 seconds	<ul style="list-style-type: none"> • Start the blood pump to eliminate the alarm and to acknowledge the error.
A87	(S) Maximum dialysate temperature	Temperature of dialysis fluid too high (> 42 °C for > 20 s) Defective heating element	<ul style="list-style-type: none"> • Inform technical service.
A88	(S) Venous pressure out of limits (PV)	Venous pressure too high or too low	<ul style="list-style-type: none"> • Ensure that: <ul style="list-style-type: none"> – venous access is free and properly connected. – venous line is not kinked, clamped or damaged.
A89	(S) Arterial pressure out of limits (PA)	Arterial pressure too high or too low	<ul style="list-style-type: none"> • Ensure that: <ul style="list-style-type: none"> – arterial access is free and properly connected. – arterial line is not kinked or clamped. • If required, reduce blood flow if arterial pressure (PA) is too low. • If required, increase blood flow if arterial pressure is too high.
A90	(S) Safety air detector (SAD) test failed	Calibration or hardware problems	<ul style="list-style-type: none"> • Switch machine off and on again.

Code	Alarm Text	Alarm Cause	Corrective Action
A91	(S) Air in venous line	Air found in venous line	<ul style="list-style-type: none"> • Clamp the venous line with the clamp between plasma filter (venous outlet) and venous chamber. • Connect a syringe to the venous chamber and manually suck out air from venous line. • Open the clamp on the venous line. • Acknowledge the alarm and continue treatment. • Readjust the level in the venous chamber using the corresponding level adjustment key.
A92	(S) 3 ml air infused	SAD has detected a total of > 3 ml air	<ul style="list-style-type: none"> • Ensure that: <ul style="list-style-type: none"> – lines have no leaks. Replace respective line if leaks are found. – all components have been connected firmly and properly. – venous chamber is sufficiently filled. If required, fill venous chamber manually.
A93	(S) Heparin pump test failed	Heparin pump slider in false position during test	<ul style="list-style-type: none"> • The heparin pump slider may not be fully inserted. Place the heparin pump slider into a different position.
A94	(S) SAD reference test error	Calibration or hardware problems	<ul style="list-style-type: none"> • Switch machine off and on again.
A95	(S) Line in SAD not empty or SAD error	Consumables already or still mounted	<ul style="list-style-type: none"> • Remove all consumables from machine.
A96	(S) Load cell not empty or load cell error	Consumables already or still mounted	<ul style="list-style-type: none"> • Remove all consumables from machine.
A97	(S) Venous pressure (PV) not zero	Consumables already or still mounted	<ul style="list-style-type: none"> • Remove all consumables from machine.
A98	(S) Arterial pressure (PA) not zero	Consumables already or still mounted	<ul style="list-style-type: none"> • Remove all consumables from machine.
A99	(S) Control system not working properly	Erroneous controller or user interface function	<ul style="list-style-type: none"> • Acknowledge the alarm (twice). If it is not possible switch machine off and on again to eliminate a possible transient failure. • If the problem cannot be solved, close treatment immediately and inform technical service.
A100	(S) SAD clock test error. Switch off and on !	Erroneous SAD clock function	<ul style="list-style-type: none"> • Switch machine off and on. • If alarm remains call service.

Code	Alarm Text	Alarm Cause	Corrective Action
A103	(S) Balance error	Balance error > 500 g Defect of plasma/buffer pump, of ultrafiltration pump or of load cell	<ul style="list-style-type: none"> • Ensure that: <ul style="list-style-type: none"> – seals of saline bags and of dialysis fluid bags are open. – lines are not kinked or clamped. – clamps on buffer line and on dialysis fluid line are open. – dialysis fluid line is inserted into support on load cell. – pump segments are correctly inserted.
A104	(S) Plasma volume error	Count error of treated plasma volume	<ul style="list-style-type: none"> • Ensure that: <ul style="list-style-type: none"> – plasma lines are not kinked or clamped. – pump segments are correctly inserted.
A105	(S) Reinfusion volume wrong (Balance)	Balance error during plasma reinfusion	<ul style="list-style-type: none"> • Ensure that: <ul style="list-style-type: none"> – pump segments (DP and UFP) are inserted properly. – lines are not kinked. – clamps on dialysis fluid and ultrafiltration line to drainage bags are open.

9.3 Warnings and Remedial Action

9.3.1 Warning Concept

Warnings are given when

- the user should perform a certain action
- a certain state must be pointed out to the user.

Warnings are always accompanied by acoustic warning tones.

Warnings which serve to point out a situation, are displayed in the Alarm/Note line.

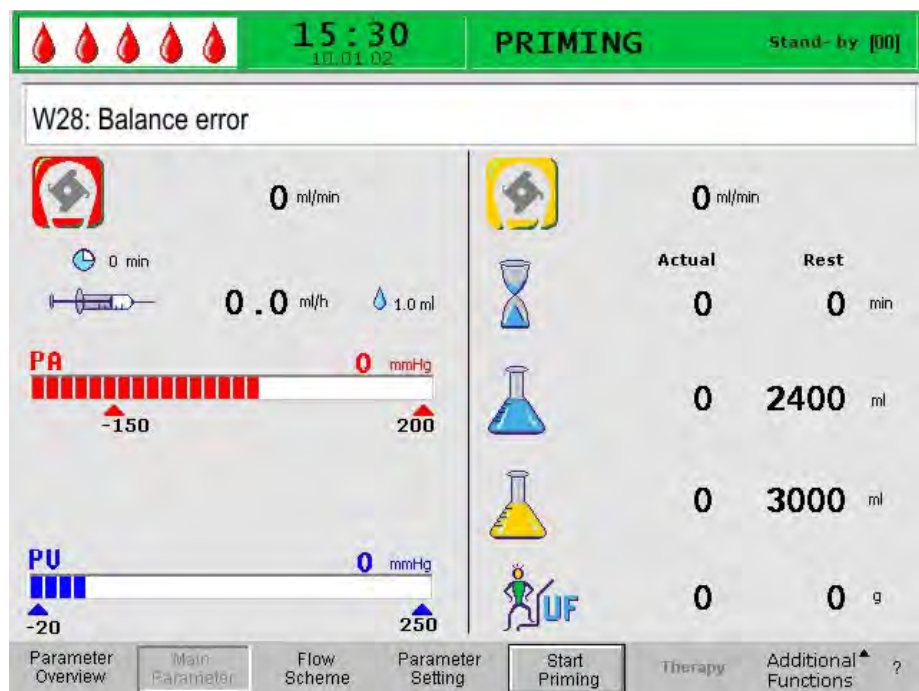

Fig. 9-3 Warning message in the Alarm/Note line

Warnings requiring an action, are displayed in a *Warning* window. These warnings must be acknowledged by pressing the *OK* key (*Press 'OK' to proceed!*) to continue in the respective phase.



Fig. 9-4 Warning message in the *Warning* window

This kind of warning is also indicated by the yellow LEDs lighting above the *OK* key (Fig. 9-5, ①).

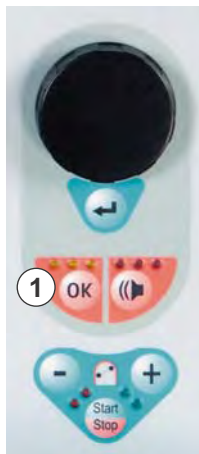

Fig. 9-5 *OK* key with yellow LEDs

9.3.2 List of all Warnings

Code	Warning Text	Warning Cause	Corrective Action
W01	Plasma pump starts after pressurization blood side	Indication that the arterial line is filled and the filling phase is continuing	<ul style="list-style-type: none"> No corrective action required.
W03	Press 'OK' to confirm safety data !	Safety query when parameters with safety relevance have been changed	<ul style="list-style-type: none"> Check setting thoroughly and confirm with the <i>OK</i> key.
W04	Turn dialyzer (blue side down) !	In the filling phase, the next handling step is indicated	<ul style="list-style-type: none"> Turn over the dialyzer and confirm with the <i>OK</i> key.
W05	Therapy interrupted for too long	Therapy interrupted for more than 5 minutes	<ul style="list-style-type: none"> Continue therapy. Select the <i>Start Therapy</i> menu item and confirm with the <i>ENTER</i> key.
W06	Therapy completed	The end of therapy is indicated	<ul style="list-style-type: none"> Press the <i>OK</i> key to change to reinfusion phase.
W08	Reinfusion interrupted for too long	Reinfusion interrupted for more than 5 minutes	<ul style="list-style-type: none"> Continue reinfusion. Select the <i>Start Reinfusion</i> menu item and confirm with the <i>ENTER</i> key.
W09	Check lines and bags !	Deviation of total weight on the load cell in bypass	<ul style="list-style-type: none"> Check the bags and lines and perform the necessary corrections. Press the <i>OK</i> key to continue.
W11	1) Connect reinfusion and buffer lines to saline solution! 2) Clamp plasma line at outlet of plasma filter ! 3) Turn plasma and precipitate filters ! 4) Turn heparin adsorber !	Information for preparing the plasma reinfusion	<ul style="list-style-type: none"> Follow the instructions on the monitor and then press the <i>OK</i> key to continue.
W12	Plasma reinfusion completed For blood reinfusion stop blood pump (do not press 'OK') or for further plasma reinfusion Press 'OK' to proceed !	Plasma reinfusion completed, information concerning the preparation for blood reinfusion	<ul style="list-style-type: none"> Follow the instructions on the monitor to change to blood reinfusion or press the <i>OK</i> key to continue plasma reinfusion.

Code	Warning Text	Warning Cause	Corrective Action
W14	Rinsing completed. For further rinsing set new value !	Minimum rinsing volume of 2400 ml reached	<ul style="list-style-type: none"> • Confirm the warning with the <i>OK</i> key. • Change to therapy phase when you consider the rinsing volume to be sufficient. • Increase the rinsing volume (see chapter 5 Priming and Rinsing (77)) and therefore extend the rinsing phase, if required (e.g. when replacing a filter during the rinsing phase).
W15	Connect buffer, check if seal and clamp are open!	Confirmation before the start of the therapy	<ul style="list-style-type: none"> • Check the positions given on the monitor and confirm with the <i>OK</i> key to continue.
W16	Press 'OK' to return to menu selection !	Information for quitting the screen when setting parameters	<ul style="list-style-type: none"> • Press the <i>OK</i> key to return from parameter setting to menu bar.
W17	Blood reinfusion completed	Information that blood reinfusion is completed	<ul style="list-style-type: none"> • Remove the venous line from the patient and terminate treatment. • Increase the blood reinfusion volume (see section 7.2 Blood Reinfusion (105)) and continue reinfusion if you consider it necessary.
W18	Break seals and open all clamps !	Confirmation at the start of priming and rinsing	<ul style="list-style-type: none"> • Follow instructions on monitor and confirm with the <i>OK</i> key to continue.
W19	Press 'OK' to exclude BLD alarms !	Is offered as an option after the 4 th BLD alarm, if 3 alarms have been confirmed before within short time	<ul style="list-style-type: none"> • Press the <i>OK</i> key to override after the fourth BLD alarm.
W20	BLD alarms excluded !	Information when the BLD alarm has been overridden by accepting the W19 option	<ul style="list-style-type: none"> • No corrective action required.
W21	1) Connect art. line to saline solution bag ! 2) Connect reinfusion line to venous chamber !	Confirmation before the blood reinfusion	<ul style="list-style-type: none"> • Check the positions given on the monitor and confirm with the <i>OK</i> key to continue.
W22	No change on arterial pressure (PA). Check PA protector !	Machine does not register a change of PA while blood pump is running	<ul style="list-style-type: none"> • Ensure that the arterial pressure transducer (PA) is correctly connected and dry. • If the error cannot be corrected, the pressure transducer or the pressure sensor is defective.
W23	Minimum dialysate inlet pressure (PDI min)	Information when the inlet pressure of dialysis fluid is too low.	<ul style="list-style-type: none"> • Ensure that the clamps on dialysis fluid line are open. • Increase plasma flow.

Code	Warning Text	Warning Cause	Corrective Action
W24	Balance error > 300 g Check lines and bags !	Balancing error of more than 300 g	<ul style="list-style-type: none"> • Ensure that: <ul style="list-style-type: none"> – bags and lines are hanging free. – there is no leakage on bags and lines. – bags are hanging motionless.
W25	Balance error > 400 g END OF THERAPY IS RECOMMENDED	Balancing error of more than 400 g	<ul style="list-style-type: none"> • Ensure that: <ul style="list-style-type: none"> – bags and lines are hanging free. – there is no leakage on bags and lines. – bags are hanging motionless. • If none of the errors listed above exists, stop therapy or perform a balance reset.

 **WARNING!**

Risk to patient due to impact on patient's fluid balance!

- Perform the balance reset only when you are sure that the balancing error was triggered by a leakage of the dialysis fluid and/or waste bags and does not concern the patient.
- If you are not able to detect the root cause, stop therapy and call technical service.

Code	Warning Text	Warning Cause	Corrective Action
W26	Reinfusion volume wrong. Check dial./UF lines and clamps!	Weight variation on load cell differs of more than ± 150 g from reinfused plasma in plasma reinfusion	<ul style="list-style-type: none"> • Ensure that: <ul style="list-style-type: none"> – buffer line is connected to saline solution. – bags and lines are hanging free.
W28	Balance error	Balancing error of > 200 g	<ul style="list-style-type: none"> • Ensure that: <ul style="list-style-type: none"> – bags and lines are hanging free. – there is no leakage on bags and lines. – bags are hanging motionless.
W29	Are you sure to reset patient balance ?	Safety query during balance reset	<ul style="list-style-type: none"> • Confirm with the <i>OK</i> key when you decided to perform a balance reset.
W30	Control system not communicating	Controller problem	<ul style="list-style-type: none"> • Switch machine off and on again. If the problem cannot be solved, inform technical service.
W31	Supervisor system not communicating	Supervisor problem	<ul style="list-style-type: none"> • Switch machine off and on again. If the problem cannot be solved, inform technical service.

Code	Warning Text	Warning Cause	Corrective Action
W32	Activate therapy mode ?	Prompt for changing to therapy phase	<ul style="list-style-type: none"> Confirm with the <i>OK</i> key.
W33	Heparin bolus	Safety query before administering the set heparin bolus	<ul style="list-style-type: none"> Press the <i>OK</i> key to administer the heparin bolus. If you do not wish to administer the heparin bolus, wait 5 s for the <i>Warning</i> window to disappear.
W34	High UF correction! UF-Filter SMC? If not, check bags for leakage	Correction value of the UF is higher than 23 %. The reason can be a leakage of the bags	<ul style="list-style-type: none"> Check the bags on the lead cell for leakages and correct connection. When using the Ultrafilter SMC, the correction value during preparation phase is higher. Therefore, this message can be ignored if leakage can be excluded.
W35	Activate reinfusion ?	Prompt for changing to reinfusion phase	<ul style="list-style-type: none"> Press the <i>OK</i> key to change to reinfusion phase.
W36	Are you sure to start a new therapy ? Return to this therapy is not possible	Information before returning to the start screen	<ul style="list-style-type: none"> Press the <i>OK</i> key if you wish to return to the start screen.

NOTICE!

All data of the currently performed therapy are deleted when you quit the reinfusion phase by pressing the OK key.

Code	Warning Text	Warning Cause	Corrective Action
W37	Selftest completed. Check characters, key LEDs, then press ENTER!	Confirmation of the successfully performed initial self test	<ul style="list-style-type: none"> Select the <i>END</i> menu item in the menu bar and press the <i>OK</i> key.
W38	Blood leakage detected. Visible blood in plasma line: Reduce plasma flow or change plasma filter and acknowledge alarm! In any other cases (to recalibrate BLD): Press 'OK' to proceed !	Blood in the plasma line or blood leak detector (BLD) defective	<ul style="list-style-type: none"> Check the plasma filter for rupture and change it if necessary. When confirming with the <i>OK</i> key, the blood leak detector will be recalibrated. Blood leak measurements will be done using the new calibration level. Blood leak measurement restarts when confirming alarm A 36 with the <i>Alarm</i> key. When the BLD alarm occurred three times within short time it is possible to mute the BLD function at the 4th alarm (W19/W20).

Code	Warning Text	Warning Cause	Corrective Action
W39	Power fail eliminated Check lines, filters and parameter setting, then restart !	Information after a power failure	<ul style="list-style-type: none"> Press the <i>OK</i> key after verification of the required positions to continue therapy. Confirm the appearing safety request <i>Are you sure?</i> by pressing the <i>OK</i> key again.
W41	Open plasma clamp and close venous clamp !	Information in blood reinfusion phase	<ul style="list-style-type: none"> Follow the instructions on the screen.
W42	Set plasma flow is too low. Increase blood or plasma flow !	Information that the required plasma flow is too low (< 2 ml/min)	<ul style="list-style-type: none"> Increase blood flow or increase plasma flow to increase plasma flow rate.
W43	Attention ! Precipitate filter rupture possible. Check prec.chamber level, PPF protector and connection Or check air bubbles in chamber and chamber locking !	Precipitate chamber level is too high, PPF protector is wet. No PPF pressure increase in case of closed HAK. (This warning appears together with alarm A73.)	<ul style="list-style-type: none"> Ensure that: <ul style="list-style-type: none"> precipitate chamber level is not too high and PPF protector is not wet. PPF protector is connected properly. precipitate chamber is positioned and level sensor is locked properly. no air bubble is attached to inner chamber wall. Press the <i>OK</i> key after examination to continue therapy.
W44	Patient balance too high or plasma flow too low. Please adjust !	Required patient balance cannot be reached in the remaining therapy time. Balance error might occur later during the course of the treatment.	<ul style="list-style-type: none"> Reduce patient balance value or increase plasma volume value or increase plasma flow value.
W45	Dialysate bags nearly empty. Change bags if necessary !	Not enough dialysis fluid for the selected treatment. Selected plasma/dialysis fluid ratio requires more fluid than available in the bags on the load cell.	<ul style="list-style-type: none"> Prepare further bag with dialysis fluid and change the bags. Change full drainage bag against empty one if necessary. Check plasma/dialysis fluid ratio.
W49	High UF correction for long time. Check lines and clamps!	Balance error	<ul style="list-style-type: none"> Ensure that: <ul style="list-style-type: none"> pump segments (DP and UFP) are inserted properly. lines are not kinked. clamps connecting dialysis fluid and ultrafiltration line with drainage bags are open.

Code	Warning Text	Warning Cause	Corrective Action
W50	Buffer line flow disturbance or weight error 1) Check bag on load cell and seal broken ! 2) Check buffer line connected and clamp opened ! 3) Check plasma pump segments !	Load cell test error	<ul style="list-style-type: none"> Follow the instructions on the screen.
W51	Remove AIR from SAD by Venous Level Regulation ! 1) Close both venous and plasma lines at PV chamber! 2) Increase PV level and stop at PV < -50 mmHg! 3) Open both lines at PV and acknowledge alarm! 4) Decrease PV level and stop at PV > 0 mmHg !	SAD detected air in the venous line	<ul style="list-style-type: none"> Follow the instructions on the screen to remove air from the venous line.
W52	Plasma pump is too slow. Check and decrease PPL Threshold !	Plasma/buffer pump runs constantly with 2 ml/min	<ul style="list-style-type: none"> Adapt the PPL threshold to the current PPL. Increase plasma flow by increasing blood pump speed and/or plasma pump speed.
W53	Reinfusion volume error > 300 g Check dialysate and UF line clamps opened !	Balance error > 300 g	<ul style="list-style-type: none"> Ensure that: <ul style="list-style-type: none"> bags and lines are hanging free. there are not leaks in bags/lines. bags are hanging motionless.
W54	Reinfusion volume error > 400 g END OF REINFUSION IS RECOMMENDED	Balance error > 400 g	<ul style="list-style-type: none"> Ensure that: <ul style="list-style-type: none"> bags and lines are hanging free. there are not leaks in bags/lines. bags are hanging motionless. If none of the errors mentioned above exists, stop therapy and perform a balance reset.
W55	Plasma Reinfusion connection error 1) Check reinfusion line connected to NaCl bag ! 2) Check buffer line connected to NaCl bag, too ! 3) Check clamps of both lines opened !	Pressure test error at beginning of reinfusion	<ul style="list-style-type: none"> Ensure that: <ul style="list-style-type: none"> plasma reinfusion line is connected with upper rinsing bag. clamps and seals are open and plasma reinfusion line is not kinked.

Code	Warning Text	Warning Cause	Corrective Action
W56	Weight of bags is too low on the load cell 1) Check that the proper kit is applied ! 2) Check acetate buffer/ all dialysate bags hanging !	Wrong weight on load cell	<ul style="list-style-type: none"> • Check the selected treatment volume and the number of BicEL bags on load cell. • Add further bag(s) if necessary. • Is the (empty) rinsing bag changed against the acetate buffer bag? • Check for correct position of the bags on load cell.
W57	Plasma volume > 4 l Change buffer bag and check dialysate bags !	Information plasma volume > 4 l	<ul style="list-style-type: none"> • Change empty buffer bag against new one. • Check number of BicEL bags. • Check drainage bags and remove full bags if necessary (upper limit of weight on load cell: 25 kg).
W58	Acetate buffer bag connection error 1) Check buffer bag is hung on the load cell ! 2) Check buffer line connected to the buffer bag ! 3) Check clamps on the line and bag opened !	Machine detected too low delivery rate of the plasma buffer pump due to too low PPF	<ul style="list-style-type: none"> • Check for correct connection of acetate buffer bag and buffer line. • Ensure that clamps and seals are open. • Check that buffer line is free and not kinked.
W59	Acetate buffer bag connection test is in progress.	Machine tests correct connection of acetate buffer bag at beginning of therapy. Both dialysis pumps (DP/UFP) are standing still during the test.	<ul style="list-style-type: none"> • No corrective action required.
W60	Reinfusion bag connection test is in progress.	Machine tests correct connection of NaCl bag at beginning of reinfusion. Both dialysis pumps (DP/PBP) are standing still during the test.	<ul style="list-style-type: none"> • No corrective action required.

9.4 Problem Correction

9.4.1 Balance Reset

Balance Error > 200 g

For a balance error > 200 g, the alarm *A69: Balance error* and the warning *W28: Balance error* are displayed.

1. Check that bags are hanging correctly on load cell.
2. Check that all seals and clamps are open.
3. Check that all lines are free from kinks.
4. After eliminating cause of error, press *Alarm* key to acknowledge alarm and *OK* key to proceed.



The warning *W28: Balance error* is displayed until the balance error has been compensated.

Balance Error > 300 g

If the balance error remains and exceeds a value of 300 g, the alarm *A69: Balance error* is initiated and the warning *W24: Balance error > 300 g. Check lines and bags !* is displayed.

1. Check machine as described above.
2. After eliminating cause of error, press *Alarm* key to acknowledge alarm and *OK* key to proceed.



The warning *W28: Balance error* is displayed until the balance error has been compensated.

Balance Error > 400 g

If it was not possible to correct the balance error with the measures described above and it exceeds a value of 400 g, the alarm *A69: Balance error* is initiated again and the warning *W25: Balance error > 400 g. END OF THERAPY IS RECOMMENDED* is displayed.

The end of therapy is recommended to exclude a balance error in the fluid balance of the patient.

Terminate therapy as described in section 6.2 End of Therapy (93)

Balance Reset

⚠ WARNING!

Risk to patient due to impact on patient's fluid balance!

- Perform balance reset only when you are sure that the balancing error was triggered by a leakage of the dialysis fluid and/or waste bags and does not concern the patient.
- If you are not able to detect the root cause, stop therapy and call technical service.

Starting with a balance error > 400 g, the *Balance Reset* menu item becomes available.



1. Select *Additional Functions* menu item in menu bar and press *Enter* key.

↳ The *Additional Functions* submenu is opened.



Fig. 9-6 *Balance Reset* menu item in *Additional Functions* submenu



2. Select *Balance Reset* menu item from *Additional Functions* submenu and press *Enter* key.

↳ The *Warning* window appears with the warning *W29: Are you sure to reset Patient Balance ?*.



3. Press *OK* key to reset Patient Balance.

↳ During a balance reset, the load cell is newly tared. The data of the balance reset are saved and shown in the *Parameter Overview* screen. Every reset performed in the course of the therapy is saved and the values are summated.



Fig. 9-7 Parameter Overview screen

9.4.2 Deaeration of the Heparin Adsorber

CAUTION!

Risk to patient due to heparin overdose!
 Permanently too low fluid levels in the heparin adsorber can result in a decreased adsorption efficiency.

- If necessary, carefully deaerate the heparin adsorber during therapy.

If the fluid level in the heparin adsorber drops during the therapy, it can be refilled.

1. Carefully open lateral heparin adsorber port during operation.
2. Wait until fluid level has increased.
3. Close port again.

9.4.3 Changing the Solution Bags



If Ecoflac containers are used, there is no break seal. Observe the instruction leaflet!

Change of Defective Bags



1. During therapy, select *Stop Therapy* menu item in menu bar and press *Enter* key.

The machine enters the bypass mode (blood pump is running, plasma-side pumps stand still).

2. Attach a clamp to the bag to be exchanged and close clamp on feed line.
3. Exchange defective bag for a new one.
4. Break seal of new bag.
5. Reopen clamp on feed line.
6. Check that all lines are free from kinks.



7. Press *OK* key to confirm warning *W09: Check lines and bags !*.



8. Select *Start Therapy* menu item in menu bar and press *Enter* key to continue therapy.

Change at a Treatment Volume > 4000 ml

At a treatment volume > 4010 ml, the machine automatically switches to bypass. The warning *W57: Plasma volume > 4 l. Change buffer bag and check dialysate bags !* is displayed. Change the buffer bag, check the dialysis fluid bag for sufficient dialysis fluid and exchange full drain bags, if necessary.

1. Attach a clamp to feeding buffer line.
2. Remove empty acetate buffer bag and replace it by a new prepared acetate buffer bag.
3. Open seal of new acetate buffer bag.
4. Reopen clamp on buffer line.
5. Check that sufficient dialysis fluid is available and replace dialysis fluid bags if necessary.
6. Check drain bags and replace if full.



7. Press *OK* key to confirm change.



8. Select *Start Therapy* menu item in menu bar and press *Enter* key to continue therapy.

Change of Nearly Empty Dialysis Fluid Bags

If dialysate/plasma ratio is > 1:2 and the dialysis fluid bags are nearly empty, the machine automatically switches to bypass. The warning *W45: Dialysate bags nearly empty. Change bags if necessary !>* is displayed.

a) Exchange if more dialysis fluid is required:

1. Attach a clamp to feeding dialysis fluid line.
2. Remove empty dialysis fluid bag and replace it by a new prepared dialysis fluid bag.
3. Open seal of new dialysis fluid bag.
4. Reopen clamp on dialysis fluid line.
5. Repeat previous steps for other dialysis fluid bags if necessary.
6. Remove full drain bags and replace them.
7. Press *OK* key to confirm subsequent warning *W09: Check lines and bags!* in *Warning* window.

b) The remaining dialysis fluid is sufficient to terminate the treatment:

1. Press *OK* key to confirm warning.

9.4.4 Changing the Plasma Filter

⚠ CAUTION!

Risk to patient due to blood clotting!

- As the blood pump is stopped, the plasma filter must be exchanged quickly to avoid blood clotting.

Materials: See key to Fig. 9-8, 1.5 ml heparin solution (5000 IU/ml)

- 1 3 l H.E.L.P. 0.9 % NaCl solution
- 2 Haemoselect L 0.5
- 3 3 x connection line
- 4 2 x collection bag

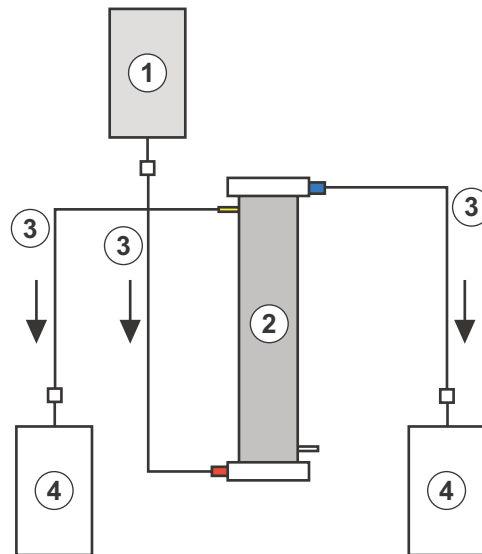

Fig. 9-8 Set-up for plasma filter rinsing

1. Mix 7500 IU heparin into the H.E.L.P. 0.9 % NaCl solution.
2. Attach a connection line to the NaCl solution, fill the line and connect it with the blood-side inlet of the filter.
3. Attach the remaining connection lines and the collection bags as shown in Fig. 9-8 with the plasma and blood side of the filter and clamp the line on the plasma side.
4. Allow the rinse solution to flow by means of gravity into the blood-side collection bag. Hold the filter so that it is filled from the bottom to the top and thoroughly vented in the process.
5. Open the plasma-side line when approx. half of the rinse solution has flown into the blood-side collection bag and clamp the blood-side line. Continue to rinse.
6. Clamp all connection lines when the remaining rinse solution has flown through (be careful that no air enters the filter!) and remove the bags.
7. Stop the blood pump, clamp the arterial and the venous plasma line, remove the old filter and then connect the new filter in the correct orientation with the lines. Close the old filter with the remaining connection lines.
8. Open blood and plasma lines and start the blood pump.



9.4.5 Changing the H.E.L.P. Precipitate Filter

Materials: See key to Fig. 9-9

- 1 3 l H.E.L.P. 0.9 % NaCl solution
- 2 H.E.L.P. precipitate filter
- 3 3 x connection line
- 4 2 x collection bag

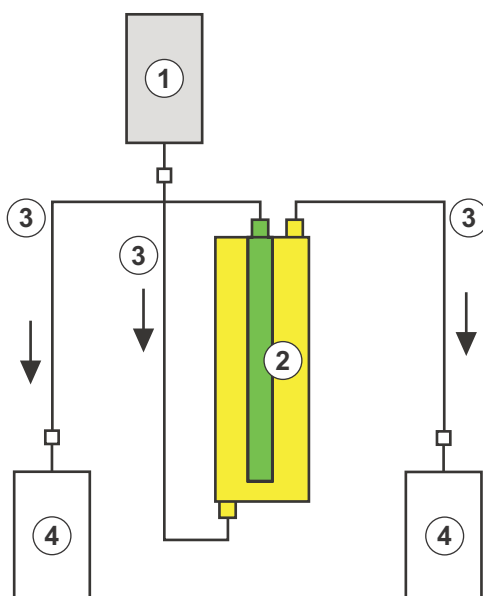

Fig. 9-9 Set-up for precipitate filter rinsing

1. Attach a connection line with the NaCl solution, fill the line and connect it with the bottom, precipitate-side filter opening.
2. Attach the remaining connection lines and the collection bags as shown in Fig. 9-9 with the upper precipitate and filtrate-side opening of the filter and clamp the line on the filtrate side.
3. Allow the rinse solution to flow by means of gravity into the precipitate-side collection bag. Hold the filter so that it is filled from the bottom to the top and thoroughly vented in the process.
4. Open the filtrate-side line when approximately half of the rinse solution has flown into the precipitate-side collection bag and clamp the precipitate-side line. Continue to rinse.
5. Clamp all connection lines when the remaining rinse solution has flown through (be careful that no air enters the filter!) and remove the bags.
6. Switch the machine to bypass mode by selecting *Stop Priming* or *Stop Therapy* in the menu bar and pressing the *Enter* key.
7. Clamp the filtrate line and the circulation line on both sides of the old precipitate filter, remove the old filter and connect the new filter in correct orientation with the lines. Close the old filter with the remaining connection lines.
8. Open circulation and filtrate lines and continue the interrupted phase by selecting *Start Priming* or *Start Therapy* in the menu bar and pressing the *Enter* key.
9. Retain the exchanged filter until the end of therapy, providing it has no leak. Connect it again in the reinfusion phase and then return the plasma. Increase the reinfusion volume accordingly.

9.4.6 Changing the H.E.L.P. Heparin Adsorber

Materials: See key to Fig. 9-10

- 1 3 l H.E.L.P. 0.9 % NaCl solution
- 2 H.E.L.P. heparin adsorber 400
- 3 2 x connection line
- 4 1 x collection bag

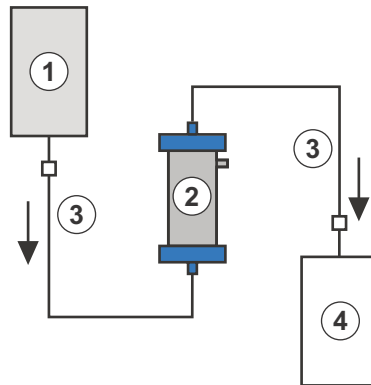

Fig. 9-10 Set-up for heparin adsorber rinsing

1. Attach a connection line with the NaCl solution, fill the line and connect it with the inlet side of the heparin adsorber.
2. Attach the second connection line and the collection bag as shown in Fig. 9-10 with outlet side of the heparin adsorber.

⚠ WARNING!

Risk to patient due to loss of heparin binding capacity!

A false flow direction and an upside-down positioning of the heparin adsorber during rinsing and treatment will cause a loss of heparin binding capacity.

- Fill and rinse the heparin adsorber according to the flow direction indicated by the red arrow at the adsorber's label.

⚠ CAUTION!

Risk to patient due to reduced heparin binding capacity!

Air residues within the capillaries of the adsorber will reduce the active surface and therefore decrease the heparin binding capacity.

- Don't rinse the saline solution too fast into the heparin adsorber to completely deaerate the capillaries and to avoid remaining air.

3. Allow the rinse solution to flow by means of gravity into the collection bag. Hold the adsorber so that it is filled from the bottom to the top and thoroughly vented in the process.

4. Clamp all connection lines when the rinse solution has flown through (be careful that no air enters the filter!) and remove the bags.



5. Switch the machine to bypass mode by selecting *Stop Priming* or *Stop Therapy* in the menu bar and pressing the *Enter* key.

6. Clamp the filtrate and the connection line on the adsorber, remove the old adsorber and connect the new adsorber in the correct orientation with the filtrate and the connection line (observe flow direction!). Connect the old adsorber with the connection lines on rinse solution and collection bag.



7. Open filtrate and connection lines and continue the interrupted phase by selecting *Start Priming* or *Start Therapy* in the menu bar and pressing the *Enter* key.

9.4.7 Changing the H.E.L.P. Ultrafilter

Materials: See key to Fig. 9-11

- 1 3 l H.E.L.P. 0.9 % NaCl solution
- 2 H.E.L.P. Ultrafilter HIPS 20
- 3 2 x connection line
- 4 1 x collection bag

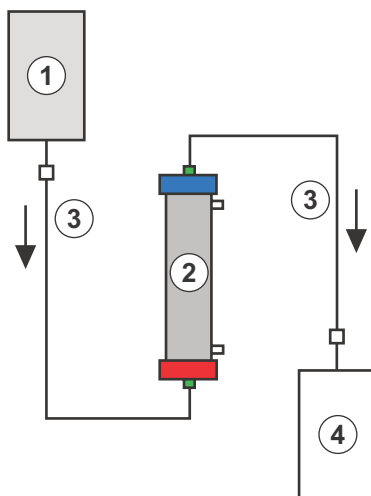

Fig. 9-11 Set-up for ultrafilter rinsing

1. Attach a connection line with the NaCl solution, fill the line and connect it with the red, plasma-side filter opening.
2. Attach the second connection line and the collection bag as shown in Fig. 9-11 with the blue, plasma-side filter opening.
3. Allow the rinse solution to flow by means of gravity into the collection bag. Hold the filter so that it is filled from the bottom to the top and thoroughly vented in the process.
4. Clamp all connection lines when approximately 1 liter rinse solution has flown through (be careful that no air enters the filter!) and remove the bags.
5. Switch the machine to bypass mode by selecting *Stop Priming* or *Stop Therapy* in the menu bar and pressing the *Enter* key.
6. Clamp the connection line and reinfusion line leading to the dialyzer, remove the old filter and connect the new filter in correct orientation to the connection and reinfusion line. Connect the old filter with the connection lines to rinse solution and collection bag.
7. Plug the Hansen connectors from the old to the new filter (hold old filter horizontally!). Observe the color marking. Insert the new filter with the blue end down into the holder.
8. Fill the dialysate side of the filter by manually turning the dialysate pump.
9. Open connection and reinfusion lines and continue the interrupted phase by selecting *Start Priming* or *Start Therapy* in the menu bar and pressing the *Enter* key.

9.4.8 Manual Blood Return

In case of power failure longer than 5 minutes during therapy, only the blood can be returned manually. For this, use the crank at the rear side of the machine (see section 2.2 Machine (26)).

⚠ WARNING!

Risk to patient due to air infusion!

During manual blood return, air detection functions are not active in the machine.

- Monitor both the patient and the machine.
- Always perform the manual blood return by two persons and with utmost care.
- Always turn the blood pump roller to the right (clockwise) as indicated by the arrows on the pump cover.

1. Open blood pump cover and fit crank onto pump roller (Fig. 9-12).



Fig. 9-12 Crank on blood pump

2. Disconnect patient arterially and connect arterial line to saline solution.
3. Remove venous line from tubing clamp.
4. Evenly turn pump roller clockwise using crank. Observe appropriate speed and maintain an adequate blood level in venous chamber.
5. Continue to monitor venous patient inlet, which may not contain any air.
6. When physiological saline solution reaches tubing clamp, close clamp on venous line.
7. Infuse additional fluid (saline solution, electrolytes) in a proper amount to compensate for the plasma lost in plasma circuit or encourage patient to drink more after therapy.
8. Disconnect patient venously.

⚠ CAUTION!

Risk to patient due to undefined plasma composition!

- Avoid manual reinfusion of plasma from the plasma circuit because this plasma is mixed with acetate buffer and, in case of power failure, the dialysis step is not enabled.

9.4.9 Remediating SAD Alarms

If the safety air detector (SAD) detects excessive air in the venous line, the tubing clamp (SAK) is automatically closed and the alarm *A37: Air in venous line. Set PV to -50 mmHg to remove the Air!* appears. Due to the reaction time, a small amount of air could be in the venous line below the SAD. This air must be removed before the treatment can be continued.



The safety air detector is not activated until beginning of therapy phase.

Removing the Air

1. Press *Alarm* key to mute alarm tone.
2. Close clamp on venous line (Fig. 9-13, ①) between plasma filter (venous outlet) and venous chamber.



If the venous line is not closed, the venous chamber will fully be filled with blood!



Fig. 9-13 Remediating SAD alarms

3. Use upper level adjustment key (Fig. 9-13, ②) to set venous pressure (PV) to -50 mmHg.
 - ↳ The tubing clamp (SAK) is opened automatically and the air is sucked from the venous line into the venous chamber.
4. Open clamp on venous line.
5. Press *Alarm* key again to acknowledge alarm.
6. Continue treatment.
7. Use level adjustment keys to set fluid level in venous chamber.

Table of contents

10	Options and Accessories	167
10.1	Options.....	167
	10.1.1 Potential Equalization Cable	167
	10.1.2 Trend Viewer	167
10.2	Accessories, Consumables and Spare Parts.....	167
	10.2.1 Consumables	168
	10.2.2 Other Accessories	170

10 Options and Accessories

10.1 Options

10.1.1 Potential Equalization Cable

When using the Plasmat® Futura machine in combination with other therapeutic devices (e.g. patient positioning devices), it is recommended to use a connection line for electrical ground, since the leakage currents from all connected devices are additive and an electrostatic discharge from the environment to the machine may occur. The optional potential equalization cable can be connected to the bolt at the rear side of the machine.

WARNING!

Risk to patient due to leakage currents when using the machine in combination with other therapeutic devices of protection class I.

- Connect electrical potential equalization also to every other therapeutic device.

10.1.2 Trend Viewer

The Trend Viewer shall only be used by technicians for acquisition of trends (e.g. therapy parameters and other internal signals) and events during therapy.

For more information about the Trend Viewer, please refer to the service manual.

10.2 Accessories, Consumables and Spare Parts

The machine shall be used only in combination with the H.E.L.P. apheresis treatment system.

Use only accessories, disposable items and spare parts that do not pose a technical safety risk and demonstrably comply with the Medical Devices Directive 93/42/EEC (MDD).

Use only accessories and spare parts whose suitability with respect to technical safety has been established and certified by an inspection authority. This verification must be carried out by an inspection authority who is authorized to inspect the ready-for-use machine.

When using the approved disposables, consumables and accessories, observe the instructions for use of the respective components.

Dispose of the consumables required for the treatment according to local regulations.

10.2.1 Consumables

For more information about consumables, inclusive article numbers for ordering, please refer to the website www.bbraun.com (Product-QuickFinder / Extracorporeal Blood Treatment / Apheresis, or search for “H.E.L.P.”).

The treatment unit for the Plasmat® Futura comprises the following consumables (disposables and solutions):

H.E.L.P. Futura Set

The H.E.L.P. Futura set includes all line systems and filters required to perform a H.E.L.P. treatment:



H.E.L.P. Futura kit with

- Haemoselect L 0.5 plasma filter
- H.E.L.P. precipitate filter
- H.E.L.P. heparin adsorber 400
- H.E.L.P. ultrafilter HiPS 20
- Venous chamber

10



Arterial line



Dialysis fluid line



1 x 5 l empty bag for rinse solution
3 x 7 l drain bags

Solutions

The H.E.L.P. treatment unit includes, in addition to the H.E.L.P. Futura set, all solutions required to perform a treatment:



2 x 3000 ml H.E.L.P. 0.9 % NaCl sodium chloride solution



1 x 4000 ml H.E.L.P. sodium acetate buffer



1 x 40 ml H.E.L.P. heparin sodium (400,000 IU)



2 x 5000 ml H.E.L.P. BicEL bicarbonate solution in a double-chamber bag



1 x 500 ml and 1 x 1500 ml H.E.L.P. 0.9 % NaCl sodium chloride solution in non-PVC bag

10

Miscellaneous

In addition, the following materials are required to perform a H.E.L.P. treatment:

- Perfusor syringe 30 ml (Omnifix®) for heparin solution
- Heparin 5000 IU/ml
- Puncture needles, cannulas, swabs
- Syringes for blood samples
- Laboratory test tubings, possibly adapters
- Tourniquets, clamps
- Skin disinfectant, gloves

10.2.2 Other Accessories

Beside the H.E.L.P. Futura set and the solutions required for treatment, B. Braun currently offers accessories from the following product areas:

- Fistula needles
- Disinfectants

For further information please contact your B. Braun representative.

Table of contents

11	Technical Data	173
11.1	General Technical Data	173
11.2	Ambient Conditions.....	174
11.3	Recommended Separation Distances	175
11.4	Technical Data of Components.....	176
	11.4.1 Relevant Pressures	176
	11.4.2 Limits of Adjustable Parameters	178
	11.4.3 Blood Side	179
	11.4.4 Plasma Circuit	182
	11.4.5 Dialyzing Circuit	184
	11.4.6 Weight System	186

11 Technical Data

11.1 General Technical Data

Parameter	Values
Power Supply	
Nominal voltage ^a	120 V~ or 230 V~
Overvoltage category	II
Rated frequency	50 Hz / 60 Hz
Rated current	max. 3.5 A at 230 V~
Power input	800 VA
Classification	
Medical devices class	II b (acc. to 93/42/EEC)
Protection class	Type B (acc. to IEC 60601-1)
Leakage currents ^b	
• Ground leakage current	< 500 µA
• Patient leakage current	< 100 µA
Machine Dimensions and Weight	
Dimensions	
• Height	1360 mm
• Width	590 mm
• Depth	620 mm
Empty weight	55 kg
Maximum weight ^c	89 kg
Miscellaneous	
Interface	RS 485 interface for connection of an external PC by technical service (detailed information on request) ^d
Potential equalization	Connection acc. to EN 60601-1 (DIN 42801)
Electromagnetic compatibility	Acc. to EN 60601-1-2 (IEC 60601-1-2)

Parameter	Values
Housing protection class	IP 21 (acc. to EN 60529: protection against foreign bodies > 12 mm and vertically falling drip water)
Housing material	Corrosion-resistant aluminum, plastics (polyurethane Baydur)

- a. The machine is configured for the specific nominal voltage indicated on the type plate.
- b. Under normal conditions. The allowed leakage currents may increase when several machines are connected.
- c. incl. maximum working load
- d. The external PC must comply with the IEC 60950 standard (or equivalent standards/ directives). Detailed information on request.

For information regarding fuse ratings and battery specifications refer to the service manual.

11.2 Ambient Conditions

Parameter	Values
Operation	
Temperature	+15 °C – +35 °C
Relative humidity	30 % – 90 %
Atmospheric pressure	700 mbar – 1060 mbar
Height	0 – 3000 m above sea level
Pollution degree class	3 (acc. to IEC 60664-1)
Transportation and Storage (dry)	
Temperature	-20 °C – +55 °C
Relative humidity	10 % – 90 %
Atmospheric pressure	700 mbar – 1060 mbar

11.3 Recommended Separation Distances

Recommended separation distances between portable or mobile HF telecommunication devices and the Plasmat® Futura machine			
<p>The Plasmat® Futura machine is made for the use in ambient conditions with controlled high-frequency (HF) disturbance variables. The user can avoid electromagnetic disturbances by keeping the distance between Plasmat® Futura and HF telecommunication devices following the values in the table below in dependency to the output power of those devices.</p>			
Nominal output power (P) of transmitter in Watt [W]	Separation distance (d) in Meter [m] depending on transmitting frequency		
	150 kHz to 80 MHz $d = 1.2 \sqrt{P}$	80 MHz to 800 MHz $d = 1.2 \sqrt{P}$	800 MHz to 2.5 GHz $d = 2.33 \sqrt{P}$
0.01 W	0.12 m	0.12 m	0.23 m
0.1 W	0.38 m	0.38 m	0.74 m
1 W	1.20 m	1.20 m	2.33 m
10 W	3.79 m	3.79 m	7.37 m
100 W	12,0 m	12,0 m	23,3 m
<p>For transmitters with other output power ratings, the recommended separation distance (d) can be calculated with the above formulas. Heed the max. power rating (P), in accordance to the manufacturer's information, to use the formula from above.</p> <p>Remark 1: For 80 MHz and 800 MHz use the higher frequency range.</p> <p>Remark 2: This guideline may be not practicable in some cases. The propagation of electromagnetic quantity will be influenced by adsorption and reflexion of the building, equipment and human.</p>			

Find more information about electromagnetic compatibility (EMC), radio disturbance and IEC 60601-1-2 in the service manual.

11.4 Technical Data of Components

Definitions

Acoustic alarm interval is the time period after which an acknowledged alarm is repeated if the cause of the alarm is still present.

Pressure working ranges are defined for normal hematocrit, blood flow rate 60 – 120 ml/min, and plasma flow rate 20 – 35 ml/min.

11.4.1 Relevant Pressures

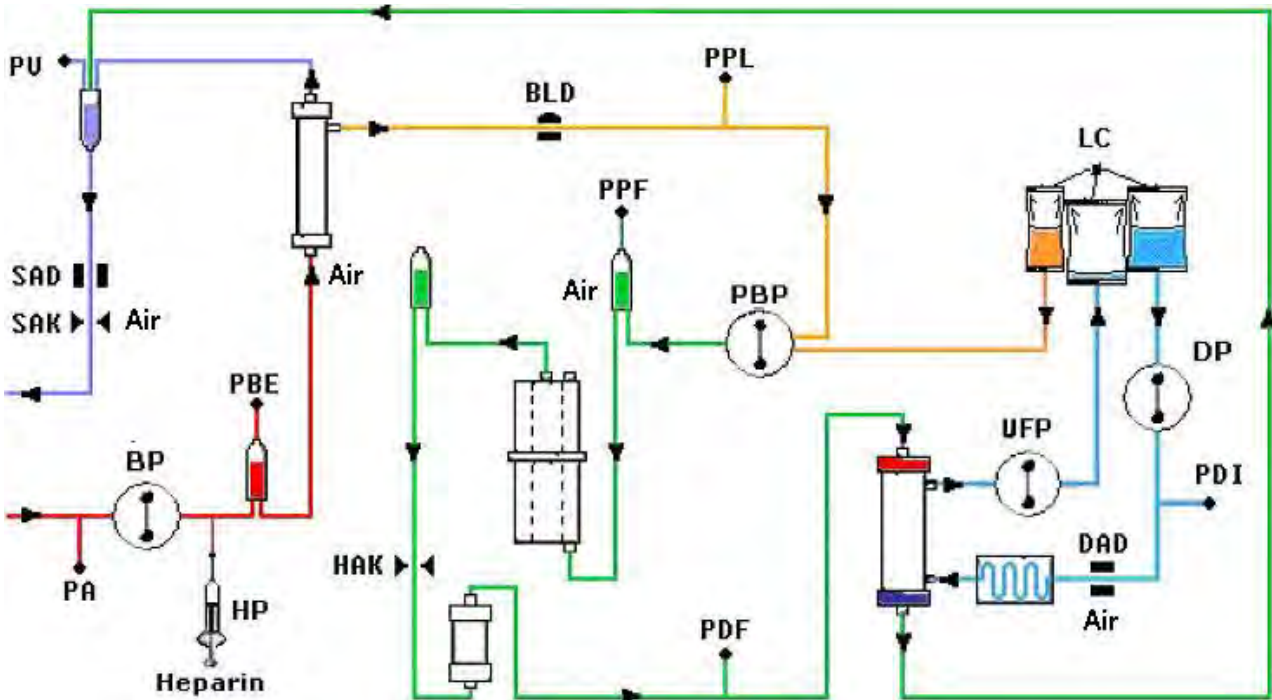

Fig. 11-1 Flow chart of Plasmat® Futura

PA Arterial pressure

PBE Arterial prefilter pressure

After the blood pump is started and adapted and the automatic level adjustment of the arterial chamber is activated, the lower and upper PBE limits are set within 10 seconds in therapy and reinfusion phase. The momentary acquired pressure (PBE Ref) serves as reference for the calculation of the alarm window.

Lower limit:
 $PBE\ min = (PBE\ Ref - 40)\ mmHg$

Upper limit:
 $PBE\ max = (PBE\ Ref + 80)\ mmHg$

The lower limit PBE min can be a minimum of -100 mmHg.
 The upper limit PBE max can be a maximum of +250 mmHg.

TMP Transmembrane pressure

The TMP is calculated as follows:

$$TMP = (PBE + PV) / 2 - PPL$$

The alarm limits can be set in 10 mmHg steps between 20 and 200 mmHg. The default setting is 70 mmHg.

11

PPL	Plasma pressure
PPF	Precipitate filter pressure
PDPA	Pressure drop precipitate filter/adsorber The PDPA is calculated as follows: PDPA = PPF – PDF
PDF	Dialyzer pressure
PDI	Dialysate inlet pressure
PV	Venous pressure During therapy and reinfusion phase, the lower and upper PV limits are automatically adjusted <ul style="list-style-type: none"> • 10 seconds after start of blood pump or plasma pump and • after change of blood flow, or • after manual level adjustment in venous or arterial chamber, respectively. The momentary acquired venous pressure (PV Ref) serves as mean value for calculation of the alarm window. Lower limit: PV min = (PV Ref – MinW) mmHg, when PV Ref > MinW PV min = 0 mmHg, when $5 \leq PV\ Ref \leq MinW$ PV min = -10 mmHg, when PV Ref < 5 MinW = Minimum PV window (default value = 20 mmHg) Upper limit: PV max = (PV Ref + MaxW) mmHg MaxW = Maximum PV window (default value = 40 mmHg)

11.4.2 Limits of Adjustable Parameters

Parameter	Default	Min	Max	Step Size	Unit
Blood flow	40	10	150	5	ml/min
Plasma flow	20	10	40	1	% ^a
Plasma reinfusion volume	400	400	1000	50	ml
Blood reinfusion volume	300	100	600	50	ml
Return flow	30	10	50	5	ml/min
Ratio dialysate/plasma	2	2	6	1	
Rinsing volume	2400	2400	20,000	100	ml
Plasma volume	3000	100	6000	50	ml
Patient balance	0	-600	0	50	g
Temperature	39	34	40	0.5	°C
Heparin flow	2	0	10	0.1	ml/h
Heparin bolus	1	0	10	0.5	ml
Autostop heparin	0	0	60	5	min
PA min	-150	-350	80	10	mmHg
PA max	100	0	200	10	mmHg
Min PV window	20	10	40	5	mmHg
Max PV window	40	20	100	5	mmHg
PPL min	-10	-20	10	1	mmHg
PPL threshold	20	-20 ^b	120	5	mmHg
TMP max	70	20	200	10	mmHg
PPF min	-20	-50	50	5	mmHg
PDF min	-50	-50	0	5	mmHg
PDF max	350	10	450	10	mmHg
PDPA max	350	50	350	10	mmHg



a. % of blood flow

b. default PPL threshold (min): -10 mmHg

11.4.3 Blood Side



Blood Pump (BP)	
	<p>Peristaltic roller pump with motor switch-off when pump cover is open</p> <p>Delivery rate: 10 – 150 ml/min</p> <p>Delivery rate tolerance: ±10 %</p> <p>Working pressure range: -140 – +500 mmHg</p> <p>Protection system: Pump status and rate are monitored via a rotation detector</p> <p>Alarm override: Not possible during therapy</p> <p>Acoustic alarm interval: 120 s</p>
Arterial Pressure (PA)	
	<p>Electronically measured by a pressure sensor and digitally displayed</p> <p>Measurement range: -500 – +500 mmHg</p> <p>Allowed tolerance: ±10 mmHg</p> <p>Working range: -60 – +10 mmHg</p> <p>During Therapy</p> <p>Default alarm limits: -150 – +100 mmHg Adjustable in parameter setting</p> <p>Protection system: Double channel pressure monitoring with sensor test during preparation phase</p> <p>Alarm override: Not possible during therapy</p> <p>Acoustic alarm interval: 120 s</p>

Prefilter Pressure (PBE)	
	<p>Electronically measured by a pressure sensor and digitally displayed</p> <p>Measurement range: -500 – +500 mmHg Allowed tolerance: ±10 mmHg Working range: +90 – +140 mmHg</p> <p>During Therapy</p> <p>Alarm limits: -100 – +250 mmHg Default alarm window: Automatic control</p> <p style="padding-left: 40px;">Lower limit: Reference value – 60 mmHg Upper Limit: Reference value + 80 mmHg</p> <p>Protection system: Sensor test during preparation phase</p> <p>Alarm override: Not possible during therapy</p> <p>Acoustic alarm interval: 120 s</p>
Venous Pressure (PV)	
	<p>Electronically measured by a pressure sensor and digitally displayed</p> <p>Measurement range: -500 – +500 mmHg Allowed tolerance: ±10 mmHg Working range: +20 – +50 mmHg</p> <p>During Therapy</p> <p>Alarm limits: 0 (-10) – +250 mmHg Default alarm window: Automatic control Parameter adjustable</p> <p style="padding-left: 40px;">Lower limit: Reference value – 20 mmHg Upper Limit: Reference value + 40 mmHg</p> <p style="padding-left: 40px;">The window limiting values are set 10 seconds after reaching the set blood flow. The reference value slowly follows the systematic pressure variation.</p> <p>Protection system: Double channel pressure monitoring with sensor test during preparation phase</p> <p>Alarm override: The absolute alarm limits cannot be overridden. The alarm window can be overridden during blood flow change/ stop, therapy start or PV level adjustment till the restabilization of PV pressure (10 s)</p> <p>Acoustic alarm interval: 120 s</p>

Safety Air Detector (SAD)	
	<p>Ultrasonic sensor on venous line below venous chamber</p> <p>Sensitivity: 0.1 ml air (bolus) or 2.0 ml air (total*)</p> <p>* Calculated integral volume of any air in form of micro-bubbles, micro-foam etc.</p> <p>Protection system: Double channel air monitoring with sensor test during preparation phase and automatic, cyclic test during therapy</p> <p>Alarm override: Not possible during therapy</p> <p>Acoustic alarm interval: 120 s</p>
Tubing Clamp (SAK)	
	<p>Electromagnetic clamp behind safety air detector to close venous return line</p> <p>It is closed in case of a blood side alarm (e.g. by air detection).</p> <p>Protection system: Double channel activation with actuator test during preparation phase</p>
Heparin Pump (HP)	
	<p>Syringe pump (calibrated to Perfusor syringe 30 ml Omnifix®)</p> <p>Delivery rate: 0 – 10 ml/h, step size 0.1 ml/h</p> <p>Delivery rate tolerance: ±10 % (below 1 ml/h after first delivered 0.05 ml)</p> <p>NOTICE In case of heparin flow below 1 ml/h, significant delivery rate error can derive when the pump starts to move the plunger because of its positioning tolerances or simply due to flexibility of the plunger.</p> <p>Working pressure range: 0 – +250 mmHg</p> <p>Protection system: Status and rate of the pumps are monitored by a rotation detector</p> <p>Alarm override: Not possible during therapy</p>



11.4.4 Plasma Circuit

Plasma/Buffer Pump (PBP, marked yellow)	
	<p>Peristaltic roller pump with motor switch-off when pump cover is open</p> <p>Delivery rate: 2 – 50 ml/min</p> <p>Delivery rate tolerance: ±10 %</p> <p>Working pressure range: -100 – +450 mmHg</p> <p>Protection system: Pump status and rate monitored via a rotation detector</p> <p>Alarm override: Not possible during therapy</p> <p>Acoustic alarm interval: 120 s</p>
Plasma Pressure (PPL)	
	<p>Electronically measured by a pressure sensor and digitally displayed</p> <p>Measurement range: -500 – +500 mmHg</p> <p>Allowed tolerance: ±10 mmHg</p> <p>Working range: +20 – +50 mmHg</p> <p>During Therapy</p> <p>Default alarm limits: -10 – +200 mmHg Lower limit adjustable in parameter setting</p> <p>Protection system: Sensor test during preparation phase</p> <p>Alarm override: Not possible during therapy</p> <p>Acoustic alarm interval: 120 s</p>



Blood Leak Detector (BLD)	
<p>BLD</p> 	<p>Photometrical red detector on disposable tubing close to plasma filter outlet</p> <p>Sensitivity: 0.25 % for detection of 0.5 ml blood in 200 ml fluid</p> <p>Avoid direct exposure to light!</p> <p>Reaction time: approx. 20 s</p> <p>Protection system: Automatic calibration and self test during preparation phase and cyclic self test during therapy. Possibility of repeating the calibration/self test at alarm during therapy.</p> <p>Alarm override: Possibility for alarm overriding during therapy when the self test/calibration failed three times. The therapy can be continued with monitoring by the user.</p> <p>A periodically occurring warning is maintained.</p> <p>Acoustic alarm interval: 120 s</p>
Precipitate Filter Pressure (PPF)	
<p>PPF</p> 	<p>Electronically measured by a pressure sensor and digitally displayed</p> <p>Measurement range: -500 – +500 mmHg</p> <p>Allowed tolerance: ±10 mmHg</p> <p>Working range: +150 – +300 mmHg</p> <p>During Therapy</p> <p>Default alarm limits: -20 – +450 mmHg Lower limit adjustable in parameter setting</p> <p>Protection system: Sensor test during preparation phase</p> <p>Alarm override: Not possible during therapy</p> <p>Acoustic alarm interval: 120 s</p>

Dialyzer Pressure (PDF)	
	Electronically measured by a pressure sensor and digitally displayed
Measurement range:	-500 – +500 mmHg
Allowed tolerance:	±10 mmHg
Working range:	+120 – +270 mmHg
During Therapy	
Default alarm limits:	-50 – +350 mmHg Parameter adjustable
Protection system:	Sensor test during preparation phase
Alarm override:	Not possible during therapy
Acoustic alarm interval:	120 s

11.4.5 Dialyzing Circuit

Ultrafiltration Pump (UFP, marked green)	
	<p>Peristaltic roller pump with motor switch-off when pump cover is open</p> <p>Delivery rate: 10 – 300 ml/min Controlled by patient balance feedback control system (based on weight measurement by load cell)</p> <p>Delivery rate tolerance: ±10 %</p> <p>Working pressure range: -100 – +450 mmHg</p> <p>Protection system: Pump status and rate monitored via a rotation detector</p> <p>Alarm override: Not possible during therapy</p> <p>Acoustic alarm interval: 120 s</p>
Dialysate Pump (DP)	
	<p>Peristaltic roller pump with motor switch-off when pump cover is open</p> <p>Delivery rate: 10 – 200 ml/min</p> <p>Delivery rate tolerance: ±10 %</p> <p>Working pressure range: -140 – +500 mmHg</p> <p>Protection system: Pump status and rate monitored via a rotation detector</p> <p>Alarm override: Not possible during therapy</p> <p>Acoustic alarm interval: 120 s</p>

11

Dialysate Inlet Pressure (PDI)	
	<p>Electronically measured by a pressure sensor and digitally displayed</p> <p>Measurement range: -500 – +500 mmHg</p> <p>Allowed tolerance: ±10 mmHg</p> <p>Working range: +60 – +80 mmHg</p> <p>During Therapy</p> <p>Default alarm limits: -50 – +450 mmHg</p> <p>Protection system: Sensor test during preparation phase</p> <p>Alarm override: Not possible during therapy</p> <p>Acoustic alarm interval: 120 s</p>
Air Detector (DAD)	
	<p>Ultrasonic sensor on dialysis fluid line behind dialysate pump</p> <p>Sensitivity: Air for 800 ms</p> <p>Protection system: Sensor test during preparation phase</p> <p>Alarm override: 40 s after alarm</p> <p>Acoustic alarm interval: 120 s</p>
Plate Warmer (H)	
	<p>Fluid warming system with temperature sensors based on heat transfer between temperature controlled metal plate and plastic dialysis fluid bag</p> <p>Temperature range: 34 – 40 °C</p> <p>Default in therapy: 39 °C</p> <p>Allowed tolerance: 0.5 °C</p> <p>Upper alarm limit: 41.5 °C for 10 s</p> <p>Protection system: Double channel temperature monitoring with sensor test during preparation phase</p> <p>Alarm override: Not possible during therapy</p> <p>Acoustic alarm interval: 120 s</p>

11.4.6 Weight System

Load Cell	
Loading capacity:	30 kg
Weight resolution:	1 g
Allowed tolerance:	±20 g
Working range:	0 – 25 kg
Overload protection:	
electrically:	at 24.5 kg
mechanically:	at 26 kg
Weight change alarm at weight deviation of:	
< 50 g:	No alarm
50 – 200 g:	Alarm after 5 s if deviation is not corrected
> 200 g:	Immediate alarm
Protection system:	Sensor test during preparation phase and monitoring of electric current through load cell bridge during therapy
Alarm override:	Not possible during therapy
Acoustic alarm interval:	120 s
Patient Balance	
Patient balance feedback control system based on weight measurement by the load cell controlling the ultrafiltration pump (marked green)	
Patient balance range:	-600 – 0 g
Allowed tolerance:	±50 g
Working range:	-600 – 0 g
During Therapy	
Alarm limits:	±200 g
Patient balance (calculated by the software from weight change) is compared continuously to the momentary theoretical value.	
Protection system:	Double channel patient balance monitoring with sensor test during preparation phase
Alarm override:	Alarm limit can be increased by 100 g by alarm acknowledge, but reaching the alarm limit ±400 g override is not possible anymore
Acoustic alarm interval:	120 s